

***KOFLOW***

---

## BALL VALVES

### Ball Valve Model Schedule Illustration

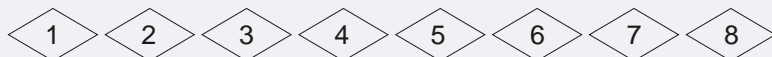

#### ① Codes of Nominal Diameter

British series indicated by A××in value, and metric series indicated by G××mm value.

#### ② Codes of Driving Modes (For handle or lever drive, this code can be omitted.)

3—Manual Operator; 6—Pneumatic; 6S—Pneumatic Spring Return; 6A—Pneumatic Control; 5—Gear Drive;  
7—Hydraulic; 8—Airdraulic; 8H—Airdraulic with Emergency Cutoff; 9—Electric

#### ③ Codes of Valve Types

FB—Float Ball Valve; TB—Fixed Ball Valve

#### ④ Codes of Nominal Pressure Class

1—PN1.6 class150; 2—PN2.5; 3—class300; 4—PN4.0 class400; 6—PN6.4 class600  
9—class900; 10—PN10.0; 15—class1500; 16—PN16.0; 20—PN20.0; 25—class2500;

#### ⑤ Codes of Connecting Modes

RF—Raised Face Flange; FF—Fully Flat Face Flange; MFM—Male and Female Flange; TG—Tongued and Grooved Flange;  
RJ—Ring Junction Flange; BW—Butt Welding; SW—Socket Welding; NPT—Threaded Connection

#### ⑥ Codes of Structural Modes

1—Full Bore Straightway; 2—Reducing Straightway; 3T—T-shaped Three-Way; 3L—L-shaped Three-way; 4—Four-way;  
5—Overall Top Installed (Full Bore); 5A—Overall Top Installed (Reducing); 6—Track Ball Valve (Full Bore); 6A—Track Ball Valve (Reducing);  
7H—Eccentric Half Ball; 7F—Eccentric Full Ball; 8—All Welded (Full Bore); 8A—All Welded (Reducing)

#### ⑦ Codes of Shell Materials

C—WCB; C5—C5; C6—WC6; C9—WC9; BL—LCB; CL—LCC  
8—CF8; 8M—CF8M; 3—CF3; 3M—CF3M; ML—MONEL

#### ⑧ Codes of Ball Materials

1—WCB; 2—CF8; 3—CF8M; 4—CF3; 5—CF3M  
1F—A105or25 2F—304; 3F—316; 4F—304L; 5F—316L

#### ⑨ Codes of Seat Materials

F—PTFE; N—Nylon; G—Carbon Fiber; P—PPL; E—PEEK; M—MOLON

**Note:**\* The letters of “K”、“E”、“O” and “J” are placed in front of the codes of valve types, respectively representing hydrogen sulphide resistant, extension bar, oxygen, and jacketed ball valve.

**Example:** A8 " TB3RF1C2F means API 8 " worm gear drive, fixed ball valve, 300Lb, raised face flange, full bore, body material WCB, ball material CF8, and seat of F4.

\* The figures mentioned hereunder don't have the codes of caliber and valve material, they are to be specified by users.

### Technical Specifications of Ball Valve

Technical Specifications	API Series	GB Series
Design Specifications	API6D、API608、BS5351	GB/T12237、JB/T7745
Pressure and Temperature Class	ASME B16.34	GB/T9124
Face-to-face	ASME B16.10	GB/T12221、GB/T15188.1
Flange Type and Dimensions	ASME B16.5、ASME B16.47	GB/T9113、JB/T79
Butt Welded	ASME B16.25	GB/T12224
Socket Welded	ASME B16.11	/
Threaded	ASME B16.1.20	/
Inspection and Test	API598、API6D	JB/T9092、GB/T13927
Fireproofing Test	API6FA、API607	JB/T6899-1993
Quality Inspection of Cast Steel Body	MSS -SP-55	JB/T9092-1999

# FLOATING BALL VALVE

## Structural Diagram of Floating Ball Valve

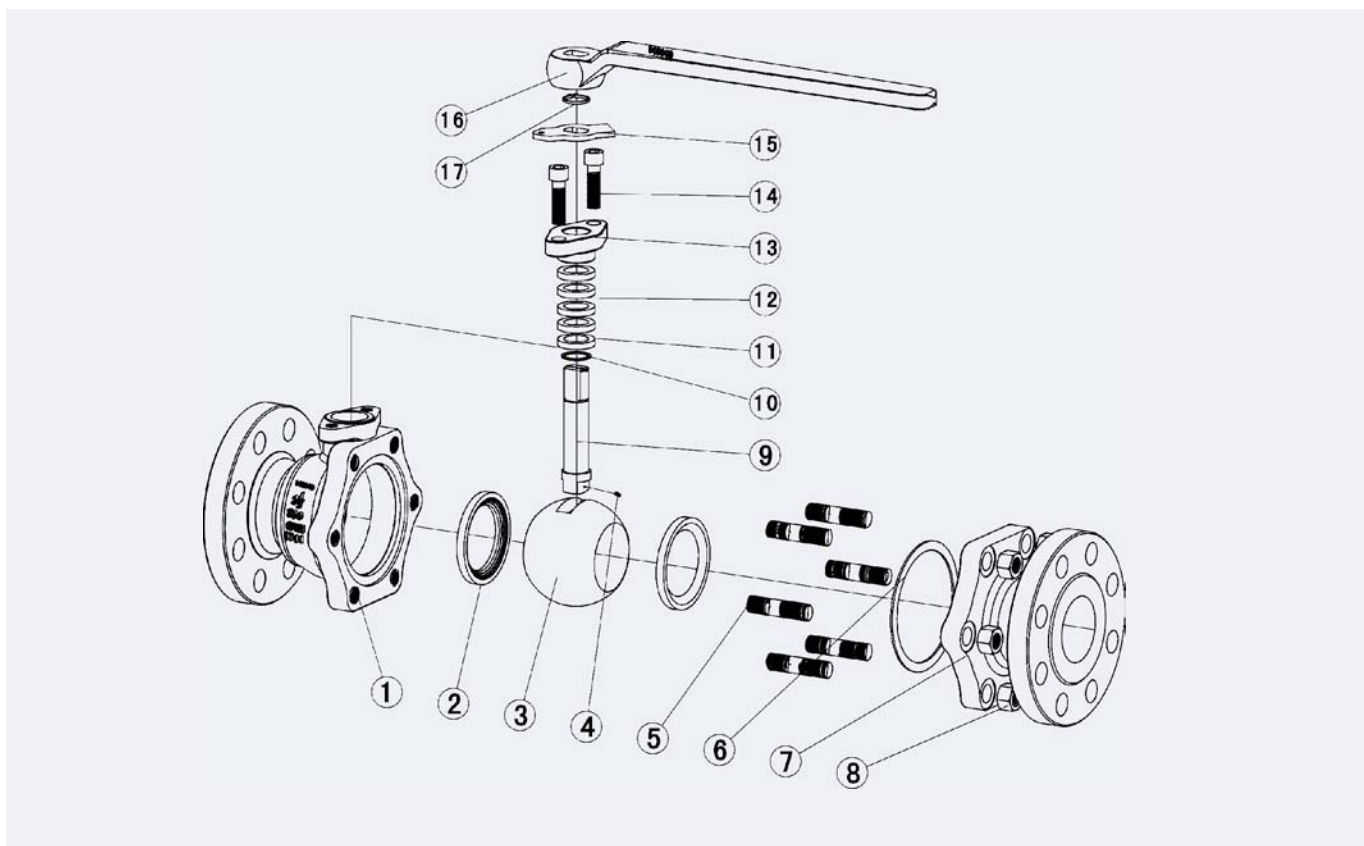

### Materials of Main Parts

No.	Part Name	Carbon Steel Series	Stainless Steel Series	Low Temperature Steel Series	Anti-sulfur Series	
					Carbon Steel Series	Stainless Steel Series
1	Valve Body	A216 WCB	A351-CF8、CF8M、CF3、CF3M	A352 LCB、LCC	GB/T12229 A216 WCB	A351 CF8M
2	Valve Seat	PTFE, RPTFE, sintered carbon fibre, metal + rubber components				
3	Ball	A105+ HCr/ENP	A351-CF8、CF8M、CF3、CF3M	A352 LCB、LCC+ENP	A105+ HCr/ENP	A351 CF8M+ENP
4	Spring	INCONEL 750				
5	Stud	A193 B7	A193 B8、B8M	A320 L7	A193 B7M	A193 B8M
6	Gasket	Flexible graphite + stainless steel				
7	Nut	A194 2H	A194 8M	A194 4	A194 2HM	A194 8M
8	Bonnet	A216 WCB	A351 CF8、CF8M、CF3、CF3M	A352 LCB、LCC	GB/T12229 A216 WCB	A351 CF8M
9	Valve Stem	A182 F6a	A182 F304、316	A182 F6a	A182 F304	A182 F316
10	Bushing	Metal with PTFE lining, sintered carbon fibre				
11	Packing Seat	A182 F6a		A182 F6a	A182 F6a	
12	Packing	Flexible graphite, PTFE				
13	Packing Gland	A216 WCB	A351 CF8、CF8M	A351 CF8	GB/T12229 A216 WCB	A351 CF8M
14	Bolt	A193 B7	A193 B8、B8M	A320 L7	A193 B7M	A193 B8M
15	Spacer	GB/T 700 Q235A+Zn(Cr)				
16	Ring	GB/T 1222 65Mn				
17	Handle	A216 WCB				

## FLOATING BALL VALVE

### Range of Supply

Nominal Diameter		Nominal Pressure					Class			
DN	In	1.6	2.5	4.0	6.3	10.0	150	300	400	600
15	1/2			●/△					●/△	
20×15	3/4×1/2			●/△					●/△	
20	3/4			●/△					●/△	
25×20	1×3/4			●/△					●/△	
25	1			●/△					●/△	
32	1			—					—	
40×32	1 1/2×1 1/4			●/△					●/△	
40	1 1/2			●/△					●/△	
50×40	2×1 1/2			●/△					●/△	
50	2			●/△/★					●/△/★	
65×50	2 1/2×2			●/△/★					●/△/★	
65	2 1/2			●/△/★					●/△/★	
80×65	3×2 1/2			●/△/★					●/△/★	
80	3			●/△/★					●/△/★	
100×80	4×3			●/△/★					●/△/★	
100	4			●/△/★					●/△/★	
125×100	5×4	●/△/★			/		●/△/★			/
125	5	●/△/★			/		●/△/★			/
150×100	6×4			●/△/★					●/△/★	
150	6	●/☆/△/★			/		●/☆/△/★			/
200×150	8×6	●/☆/△/★			/		●/☆/△/★			/
200	8	●/☆/△/★			/		●/☆/△/★			/

Note: ● stands for handle operated valves;  
 ☆ stands for gearbox operated valves;  
 △ stands for air operated valves;  
 ★ stands for electrically operated valves;  
 / stands for no option of this.  
 Those not covered in the table can be custom made to users' requirements.

### Product Performance Specifications

Performance Specifications		Nominal Pressure(Mpa)					Class			
		1.6	2.5	4.0	6.4	10.0	150	300	400	600
Test Pressure	Strength Test	2.4	3.75	6.0	9.6	15.0	2.93	7.58	10.0	15.0
	Seal Test	1.76	2.75	4.4	7.04	11.0	2.07	5.52	7.31	11.03
	Air Pressure Test	0.6 MPa								
Suitable Temperature		-196 °C~550 °C (Note: different materials to be used to deal with different ambient temperature)								
Suitable Medium	Conventional Type	Water, steam, petroleum, LPG, natural gas and etc.								
	Anti-sulfur Type	Natural gas containing H <sub>2</sub> S or CO, and petroleum etc.								

# FLOATING BALL VALVE

## Structural Features

### 1. Switch Indication of Hand Operated Float Ball Valve

Floating ball valves are the superior products, manufactured by our company after absorbing advanced technology at home and abroad with wadded design concept, which can need safety and convenience require mend of general industry standards

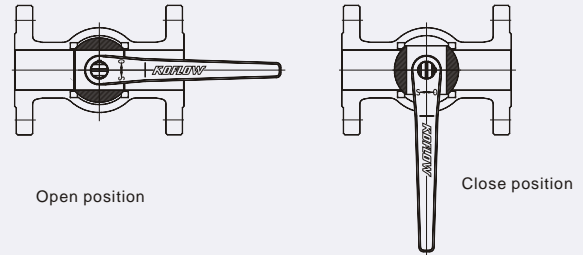

Reasible design of on/off

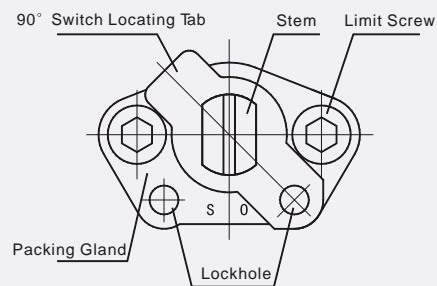

90° Switch with Lockhole Locating Tab

### 2. Valve Locking Device

To prevent misoperation, the fully opened or closed position of valve can be locked up, especially when valves are mounted outdoors or when valves are not allowed to be opened or closed by technical process. To prevent misoperation by other persons, it seems very important to have valve position locked up. Thereby based on needs, lockhole locating is designed if requested by users to meet the technological requirements of users.

### 3. Anti-flyout Structure of Valve Stem

When medium passes through the valve, the pressure in valve body may possibly push the stem out, ( when the valve is in repair, if there is pressure in the middle cavity, the stem or medium seems to easily fly out upon disassembling the valve, which can cause injuries to human beings). To prevent these possibilities, a dummy club is placed at the lower part of the stem. In this way, even if there is a fire, packing and thrust bearing are burnt or packing is damaged due to other causes, the pressure of medium in valve body will make the dummy club of valve stem in close contact with the upper seal face of valve body, thus to prevent medium leaking out from the damaged packing position.

### 4. Antistatic Device

When operating the valve, the friction between the ball and the nonmetal seat, like PTFE . will produce electrostatic charge that can be accumulated on the ball. To prevent static spark, an antistatic device is placed on the valve to derive the electric charge accumulated on the ball though the static channel between the ball and the stem, or between the stem and valve body.

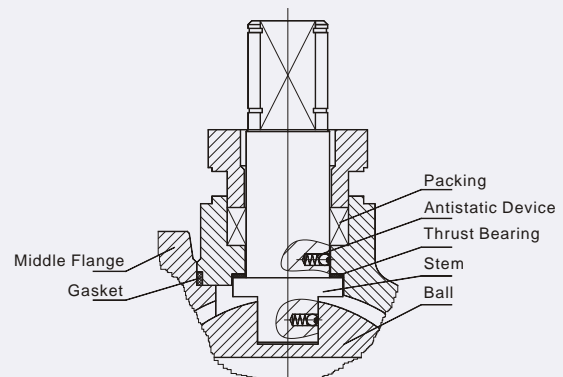

Stem Anti-flyout Structure  
Stem Antistatic Device  
Middle Flange Leak-tight Structure

### 5. Middle Flange Leak-tight Structure

The connection between valve body and the left body is sealed by gasket. To prevent seal leakage resulted from fire, high temperature or vibration etc., the valve body and the left body is designed metal-to-metal contacted, with forms up a seal flange to ensure leak-tightness.

### 6. Fire Protection Structure

In case of fire, the nonmetal packing or seat (non-fireproof material) will be burnt, the considerable medium leakage may cause fire to spread. Here, the fire protection structure functions to prevent medium from mass leakage. As shown in the figure, once the seat is burnt, the ball will directly contact the metal face on valve body, to prevent medium leaking out from the burnt seat. The design of fire protection and antistatic structure shall conform to the requirements of API607, JB/T6899 and the second part of BS 6755.

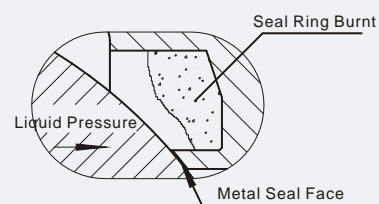

Fire Protection Structure of Float Ball Valve

## FLOATING BALL VALVE

### Structural Features

#### 7. Dependable Sealing Structure

The two-way sealing structure embodying the years of our manufacturing experience in ball valves and the international advanced technology can release the pressure at valve seat and ensure reliable seal under high or low pressure and vacuum state. When the pressure of medium is low, the contact area between valve seat seal ring and ball is relatively small, thus providing high sealing load to ensure dependable seat seal. When the pressure of medium is high, the contact area between valve seat seal ring and ball is relatively large, so that the valve seat insert can endure the considerable medium thrust and will not be damaged.

Regarding ball valves of very low working pressure, in consideration that the pressure of medium cannot guarantee the dependable seal of valve seat, and that the pretightening force will decrease after a long time of service, we apply leaf spring loaded sealing structure for valves working under low and ultralow pressure or under vacuum conditions, thus to ensure persistent and dependable seal.

The sealing structure of medium and high temperature ball valves use PPL as seal ring that can serve a temperature of 300 °C. Ball valves with metal seal and high temperature resisting materials can be used to deal with even higher temperature. This structure takes the function of one-way seal.

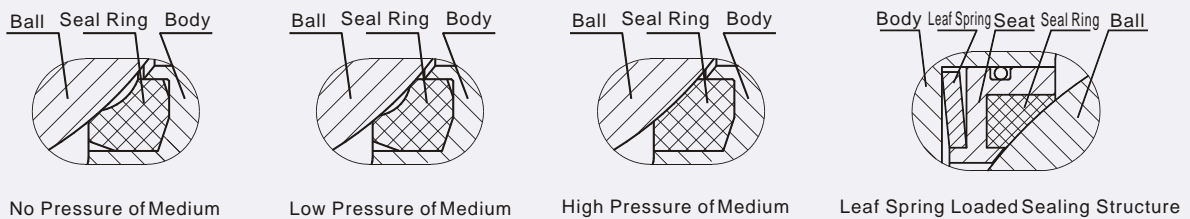

Double Bevel Elastic Seal Ring of Float Ball Valve

#### 8. Self-relieving Structure

In case of abnormal rise of pressure in the middle cavity of valve resulted from the medium left there suffered changes of pipeline pressure or medium temperature, automatic pressure relief of valve seat can be effected under the pressure of the medium itself, thus to guarantee the safety of valve.

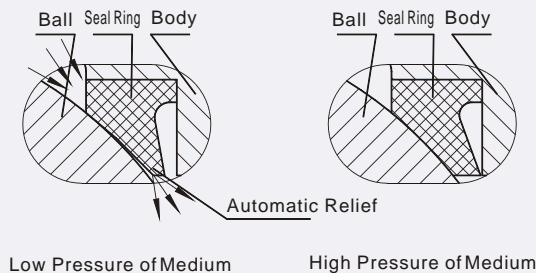

V-slot Elastic Seal Ring of Float Ball Valve

#### 9. Full and Reduced Bore

We have ball valves of full and reduced bore to meet users' different needs. Full-bore ball valves have the same inside diameter as that of pipeline, with the lowest fluid resistance for the convenience of cleaning the pipeline. While reduced-bore ball valve weighs only 70% of the full-bore ball valve with the same caliber, a saver of cost and price, and its fluid resistance coefficient is only 1/7 of that of the globe valve with the same caliber, so that reduced-bore valves are widely used abroad.

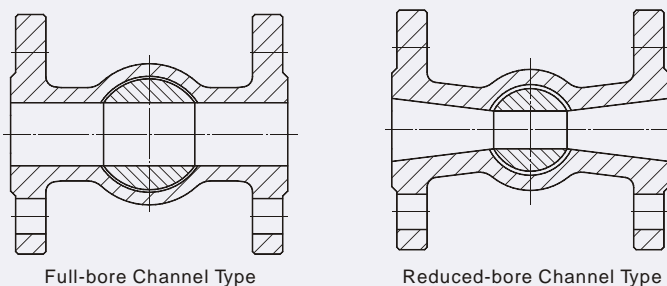

# FLOATING BALL VALVE

## Reference Torque of Floating Ball Valve

The table and graphic torques below are for reference to choose a drive device. According to the properties of medium, trims and the open frequency of valve shall be considered as extra factors. Valves with corrosion-resistant trims to deal with clean lubricating mediums, their torque may be lowered by 20%. However, to deal with stringent mediums like slurry, granular medium and oxygen, the torque may be increased by 50%.

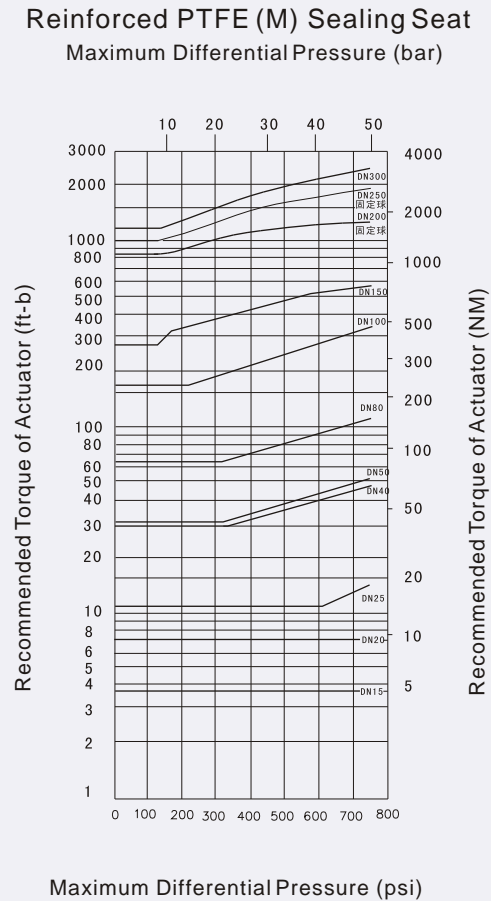
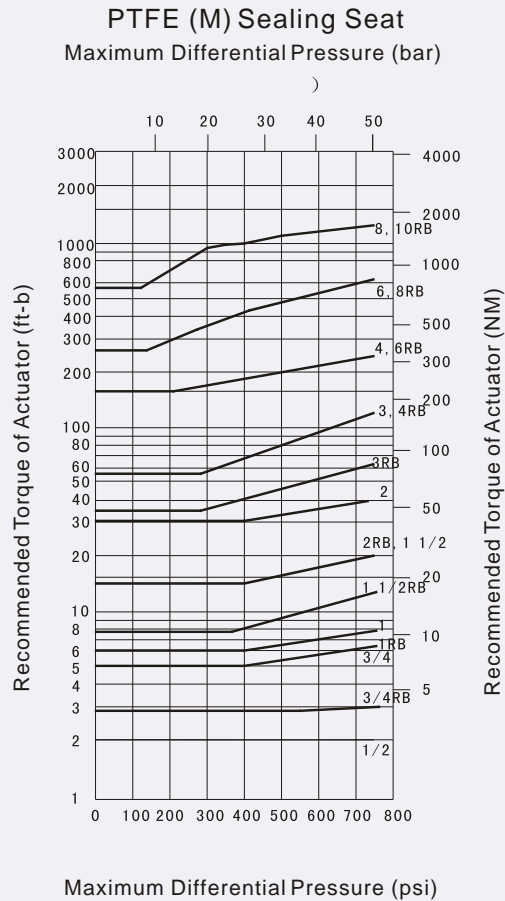

### Torque table

Pressure \ Diameter	15	20	25	40	50	65	80	100	125	150	200
PN1.6 MPa	3	5	10	16	25	50	65	125	250	340	485
PN2.5 MPa	3	5	11	18	30	60	80	140	300	400	680
PN4.0 MPa	5	10	24	35	50	100	150	250	450	585	996
PN6.4 MPa	15	30	50	80	100	200	300	400	/	/	/
PN10.0 Mpa	19	35	68	130	190	360	460	770	/	/	/

Note: the data listed is not subject to actual measurement, but for reference only.

Pressure \ Diameter	1/2	3/4	1	1 1/2	2	2 1/2	3	4	5	6	8
Class 150	3	5	11	16	25	50	65	125	250	410	700
Class 300	7	12	26	38	60	120	160	280	600	950	1550
Class 400	15	30	50	90	140	240	350	540	/	/	/
Class 600	19	35	68	130	190	360	460	770	/	/	/

Note: the data listed is not subject to actual measurement, but for reference only.

## FLOATING BALL VALVE

### Table of Options for Valve Actuators

SIZE		PN1.6、150Lb		PN2.5、PN4.0、300Lb		PN6.4、PN10.0、400Lb、600Lb	
DN	NPS	Pneumatic	Electric	Pneumatic	Electric	Pneumatic	Electric
15	1/2	AG06D	/	AG06D	/	AG09S	/
20×15	3/4×1/2	AG06D	/	AG06D	/	AG06D	/
20	3/4	AG09S	/	AG09S	/	AG09D	/
25×20	1×3/4	AG09S	/	AG09S	/	AG09S	/
25	1	AG09D	/	AG09D	/	AG09D	/
40×32	1 1/2×1 1/4	AG09D	/	AG09D	/	AG09D	/
40	1 1/2	AG13S	/	AG13S	/	AG09D	/
50×40	2×1 1/2	AG13S	/	AG13S	/	AG09D	/
50	2	AG13S	LQA5-1	AG13S	LQA5-1	AG13D	LQA40-1
65×50	2 1/2×2	AG13S	LQA5-1	AG13S	LQA5-1	AG09D	LQA40-1
65	2 1/2	AG13S	LQA10-1	AG13S	LQA10-1	AG13D	LQA40-1
80×65	3×2 1/2	AG13S	LQA10-1	AG13S	LQA10-1	AG13D	LQA40-1
80	3	AG13D	LQA10-1	AG13D	LQA10-1	AW13S	LQA80-1
100×80	4×3	AG13D	LQA10-1	AG13D	LQA10-1	AG13D	LQA80-1
100	4	AW13S	LQA20-1	AW13S	LQA20-1	AW17S	LQA80-1
125×100	5×4	AW13S	LQA20-1	AW13S	LQA20-1	/	/
125	5	AW17S	LQA40-1	AW17S	LQA40-1	/	/
150×100	6×4	AW13S	LQA20-1	AW13S	LQA20-1	AW17S	LQA80-1
150	6	AW17S	LQA40-1	AW17S	LQA40-1	/	/
200×150	8×6	AW17S	LQA40-1	AW17S	LQA40-1	/	/
200	8	AW20S	LQA80-1	AW20S	LQA80-1	/	/

Note: the types of pneumatic actuator listed are from Alpha, and the types of electric actuators are from Tianjin Beifang Valve Actuator Co., Ltd.

### Output Torque of Electric Actuator (NM)

Type	Output Torque	Stem Diameter	Output Speed	Motor Power
LQA5-1	50	20	1r/min	0.016KW
LQA10-1	100	20	1r/min	0.03 KW
LQA20-1	200	20	1r/min	0.06 KW
LQA40-1	400	35	1r/min	0.09 KW
LQA80-1	800	35	1r/min	0.18 KW

### Type and Specifications of Pneumatic Actuator

Double-acting Type	Single-acting Type (Spring Return)		
	Standard Type	High Output Type	Low Pressure Type
AG06	AG06S	AG06D	AG06R
AG09	AG09S	AG09D	AG09R
AG13	AG13S	AG13D	AG13R
AW13	AW13S	/	AW13L
AW17	AW17S	/	AW17L
AW20	AW20S	/	AW20L

Note: the output torque of pneumatic actuator is subject to the data from the manufacturer's sample book.



## FLOATING BALL VALVE

### Datasheet of Flow Rate

Flow coefficient is an index to measure the flow capacity of a valve. A higher value of flow coefficient means less pressure loss of fluid passing through the valve. The value of flow coefficient varies according to the dimensions, type and structure of valve. Valves of different types and specifications shall be tested separately to make sure of their values of flow coefficient. Regarding valves of the same structure, flow coefficient varies according to the flow direction of fluid through the valve. Generally, these differences are caused by different pressure recoveries.

The table below is the flow coefficient of float ball valve. 'Cv' stands for the American gallons flowing through the valve per minute under 1pound/inch<sup>2</sup> ( 0.006894757MPa ) pressure drop + 60°F (+16°C) water.

### Cv

Nominal Diameter	1/2	3/4	1	1 1/4	1 1/2	2	2 1/2	3	4	5	6	8
Reduced Bore	9	19	45	-	125	165	270	350	550	670	765	1890
Full Bore	25	50	100	-	270	490	950	1160	2200	3800	5100	9300

### Pressure-Temperature Rating

The pressure-temperature rating of ball valve is not only related to shell materials, but also to the sealing parts of seat, packing and gasket etc. The materials of sealing parts may be high molecular material, graphite asbestos or rubber etc., which depends on the composition of the medium to be handled, working temperature, working pressure and flow velocity.

It is rather difficult to accurately make out the pressure temperature rating of valve under various unpredictable working conditions. Based upon the years of valve manufacturing experience and the precious feedback of users, we can offer you the pressure-temperature rating of valve under stable working conditions.

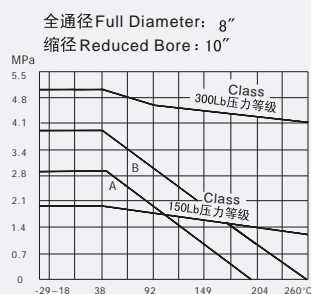
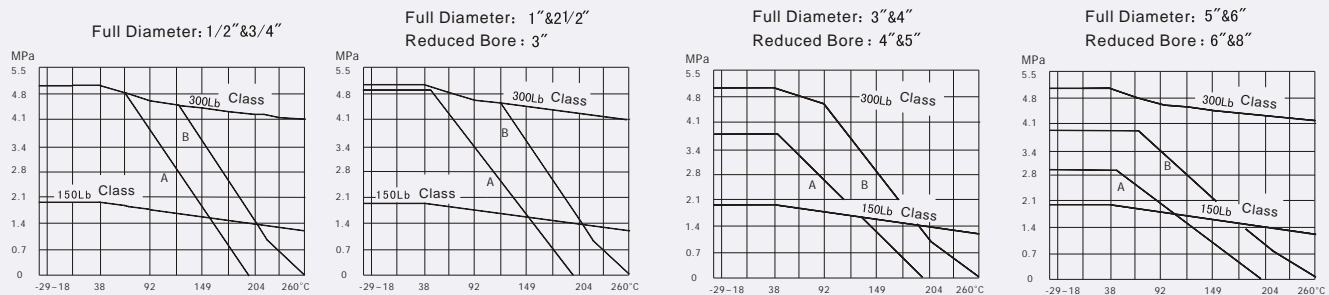

A: Pure PTFE  
B: Reinforced PTFE  
The pressure-temperature curve of the valve body in the diagram is WCB material,  
the pressure-temperature curve of other shell materials please refer to the latest edition of ASME B16.3.

## FULL BORE FLOATING BALL VALVE

PN1.6~10.0MPa CLASS 150~600

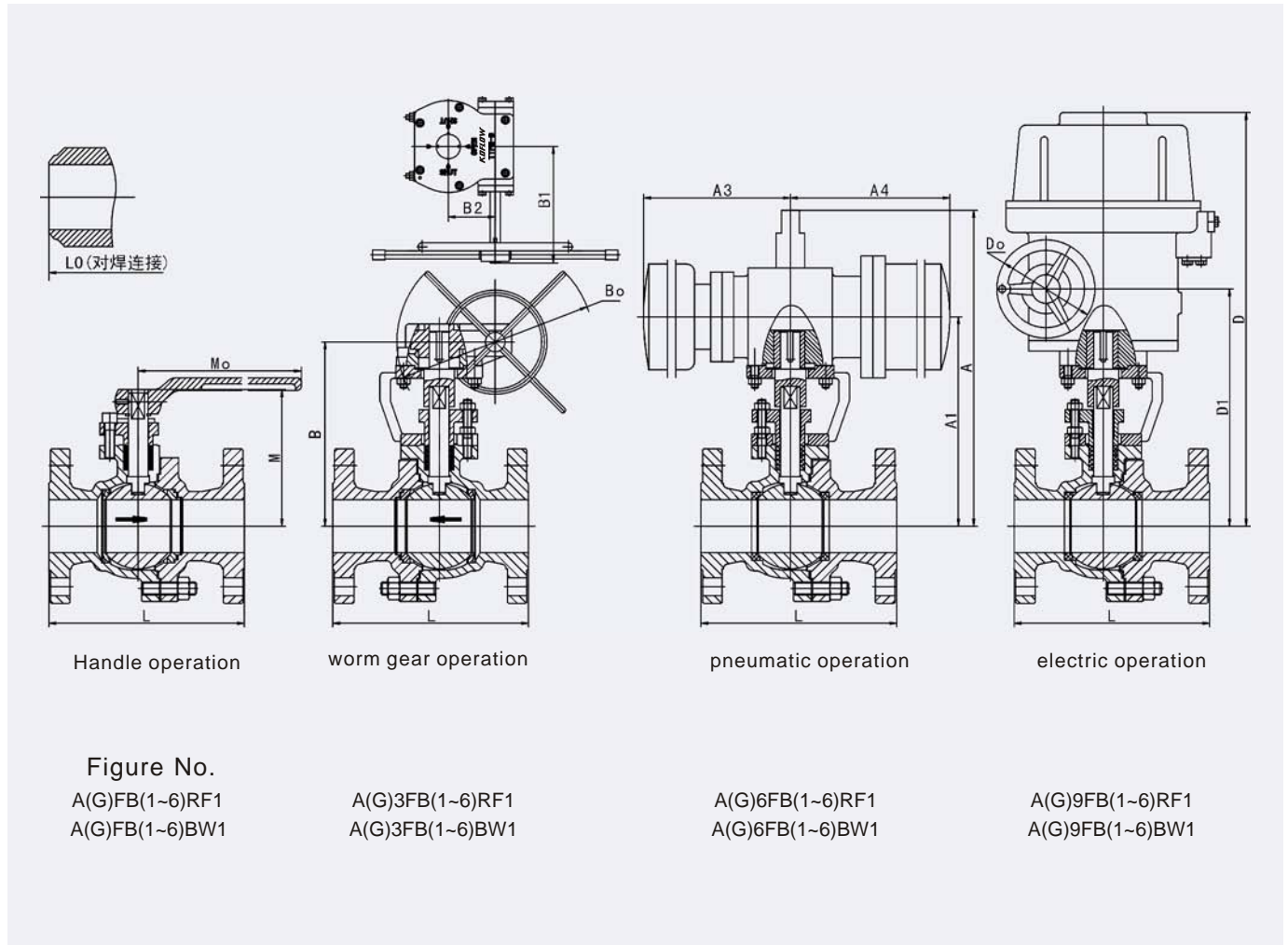

### Main Dimensions

PN1.6MPa CLASS 150 mm

DN	mm	15	20	25	40	50	65	80	100	125	150	200
NPS	in	1/2	3/4	1	1 1/2	2	2 1/2	3	4	5	6	8
L	RF	108	117	127	165	178	190	203	229	356	394	457
Lo	BW	140	152	165	190	216	241	283	305	381	457	521
Manual	M	59	63	75	95	107	142	152	178	252	272	342
	M0	130	130	160	230	230	400	400	650	1050	1050	1410
Worm and Gear	B	/	/	/	/	/	/	/	/	/	292	398
	B0	/	/	/	/	/	/	/	/	/	400	600
	B1	/	/	/	/	/	/	/	/	/	350	350
	B2	/	/	/	/	/	/	/	/	/	115.5	115.5
Pneumatic	A	200	204	257	264	340	370	389	594	646	646	781
	A1	122	126	162	169	209	239	258	337	437	437	537
	A3	326	326	347	420	426	426	590	523	610	610	885
	A4	136	136	181	181	257	257	257	287	378	378	530
Electric	D	/	/	/	/	472	486	579	595	650	739	799
	D1	/	/	/	/	377	391	484	500	500	589	649
	D0	/	/	/	/	190	190	190	190	400	400	400
(RF) Weight	Manual	2.5	3	5	7	10	15	19	33	58	93	160
	Pneumatic	10	15.7	19.5	42.8	46.9	50.5	70	92.7	160.7	183.5	276
	Electric	/	/	/	/	32	35.6	44	55	93	128	195

## FULL BORE FLOATING BALL VALVE

Main Dimensions		PN2.5、4.0MPa CLASS 300										mm
DN	mm	15	20	25	40	50	65	80	100	125	150	200
NPS	in	1/2	3/4	1	1 1/2	2	2 1/2	3	4	5	6	8
L	RF	140	152	165	190	216	241	283	305	381	403	502
Lo	BW	140	152	165	190	216	241	283	305	381	457	521
Manual	M	59	63	75	95	107	142	152	178	252	272	342
	M0	130	130	160	230	230	400	400	650	1050	1050	1410
Worm and Gear	B	/	/	/	/	/	/	/	/	/	292	398
	B0	/	/	/	/	/	/	/	/	/	400	600
	B1	/	/	/	/	/	/	/	/	/	350	421
	B2	/	/	/	/	/	/	/	/	/	115.5	171
Pneumatic	A	200	204	257	264	340	379	452	594	646	744	920
	A1	122	126	162	169	209	248	295	375	437	500	615
	A3	326	326	347	420	426	426	590	523	610	610	885
	A4	136	136	181	181	257	257	257	287	378	378	530
Electric	D	/	/	/	/	472	486	579	595	650	739	799
	D1	/	/	/	/	377	391	484	500	500	589	649
	D0	/	/	/	/	190	190	190	190	400	400	400
(RF) Weight	Manual	3	4	6	11	15	24	30	55	81	118	200
	Pneumatic	10	15.7	20	40.9	43.9	51.9	68	99.4	177.5	207.5	381
	Electric	/	/	/	/	29	37	42	77	116	143	235

## Main Dimensions

PN6.4、10.0MPa CLASS 400、600 mm

Main Dimensions		PN6.4、10.0MPa CLASS 400、600										mm
DN	mm	15	20	25	40	50	65	80	100			
NPS	in	1/2	3/4	1	1 1/2	2	2 1/2	3	4			
L	RF	165	190	216	241	292	330	356	406(432)			
Lo	BW	165	190	216	241	292	330	356	406(432)			
Manual	M	59	63	75	95	142	154	184	209			
	M0	160	160	230	400	400	650	650	1050			
Worm and Gear	B	/	/	/	/	/	/	/	292	398		
	B0	/	/	/	/	/	/	/	400	600		
	B1	/	/	/	/	/	/	/	350	421		
	B2	/	/	/	/	/	/	/	115.5	171		
Pneumatic	A	200	204	241	264	340	379	452	584			
	A1	122	145	146	169	209	248	295	375			
	A3	283	283	283	350	590	590	523	610			
	A4	136	181	181	181	257	257	287	378			
Electric	D	/	/	/	/	472	599	599	632			
	D1	/	/	/	/	377	4491	449	472			
	D0	/	/	/	/	190	190	190	190			
(RF) Weight	Manual	8	11	15	19	25	32	48	76			
	Pneumatic	17.2	21	24	32	68	75	101.3	177.5			
	Electric	/	/	/	/	60	67	83	111			

Note: the dimensions in brackets are the structural length of PN10.0 (CLASS600).