

Orifice plate

Model : F100

Spec. sheet no. FD01-01

Description

Orifice plates are widely used for flow measurement as they provide the simplest and the most economical means of flow detection. Orifice plates are available in the concentric type that the round opening (Bore) of the orifice plate is positioned concentrically with the center of the pipe and the opening edge (Bore edge) is available either in the concentric square edge type (Sharp, square edge type) or in the quadrant edge type (Round edge type). Orifice plates are also available in the eccentric type that the opening of the orifice is shifted from the center of the pipe. They also are available in the segmental type that the opening is a circular segment and the orifice is comparable to a partially opened gate valve.



Specification

Orifice bore type

Concentric square edged orifice
 Quadrant edged orifice
 Eccentric orifice
 Segmental orifice

Plate thickness

3, 6, 9 and 12 mm

Tab handle

Welded to orifice plate

Flow calculation standards

ISO 5167-1 and 2 2003
 AGA-3
 ASME MFC-3M and 14M
 JIS Z 8762
 BS 1042

Plate material

Standard : 304SS and 316L SS
 Non-standard : Monel, Hastelloy C, Titanium and etc.

Drain and vent hole

Per ASME recommendations
 Not drilled for orifice bores smaller than 25.4 mm

Flange ratings

JIS 10, 16, 20, 30, 40, and 63K
 ANSI class 150, 300, 600, 900, 1,500 and 2,500 Lb

Markings

Upstream side of tab handle stamped "Upstream" and with bore type and size, line size, tag number and flange rating

Pressure taps

Flange taps
 Corner taps
 Vena contract taps
 1D and 1/2D (Radius) taps
 Pipe taps (2 1/2D and 8D)

Special markings

Special marking may be furnished to meet special requirement

Orifice plate application summary

Orifice type	Fluid type					Nominal line size normally used	
	Gas and vapor		Liquid			JIS (mm)	ANSI (inch)
	Clean	Dirty	Clean	Dirty	Viscous		
Concentric - Square edge	E	X	E	O	X	40 ~ 1,500	1 1/2 ~ 60
Concentric - Quadrant edge	X	X	E	O	E	40 ~ 250	1 1/2 ~ 10
Eccentric - Square edge	O	O	O	E	X	100 ~ 350	4 ~ 14
Segmental - Square edge	O	O	O	E	X	100 ~ 350	4 ~ 14

Main order

Ordering information

1. Base model

F100 Orifice plate

2. Type

P1 Orifice plate

3. Line size

JIS	mm	ANSI	inch	DIN	mm
J015	15A	A001	½B	D015	15A
J020	20A	A002	¾B	D020	20A
J025	25A	A003	1B	D025	25A
J040	40A	A004	1½B	D040	40A
J050	50A	A005	2B	D050	50A
J065	65A	A006	2½B	D065	65A
J080	80A	A007	3B	D080	80A
J100	100A	A008	4B	D100	100A
J125	125A	A009	5B	D125	125A
J150	150A	A010	6B	D150	150A
J200	200A	A011	8B	D200	200A
J250	250A	A012	10B	D250	250A
J300	300A	A013	12B	D300	300A
J350	350A	A014	14B	D350	350A
J400	400A	A015	16B	D400	400A
J450	450A	A016	18B	D450	450A
J500	500A	A017	20B	D500	500A
J600	600A	A018	24B	D600	600A
J700	700A	A019	28B	D700	700A
J800	800A	A020	32B	D800	800A
J000	1,000A	A021	40B	D000	1,000A
XXXX	Other				

4. Bore type

C Concentric edge
E Eccentric
Q Quadrant edge
S Segmental

5. Flange rating

JIS	ANSI	DIN
J010	JIS 10K A010 ANSI 150 Lb	P010 PN 10
J016	JIS 16K A020 ANSI 300 Lb	P016 PN 16
J020	JIS 20K A030 ANSI 600 Lb	P025 PN 25
J030	JIS 30K A040 ANSI 900 Lb	P040 PN 40
J040	JIS 40K A050 ANSI 1,500 Lb	
J063	JIS 63K A060 ANSI 2,500 Lb	

6. Material

4 304SS
6 316L SS
H Hastelloy-C
M Monel
O Other

7. Drain / vent

D Drain (Not drilled for orifice bores smaller than 25.4 mm)
V Vent (Not drilled for orifice bores smaller than 25.4 mm)
N None

8. Options

O Other
N None

1	2	3	4	5	6	7	8
F100	P1	J150	C	J020	6	D	O

Sample ordering code

Dimension

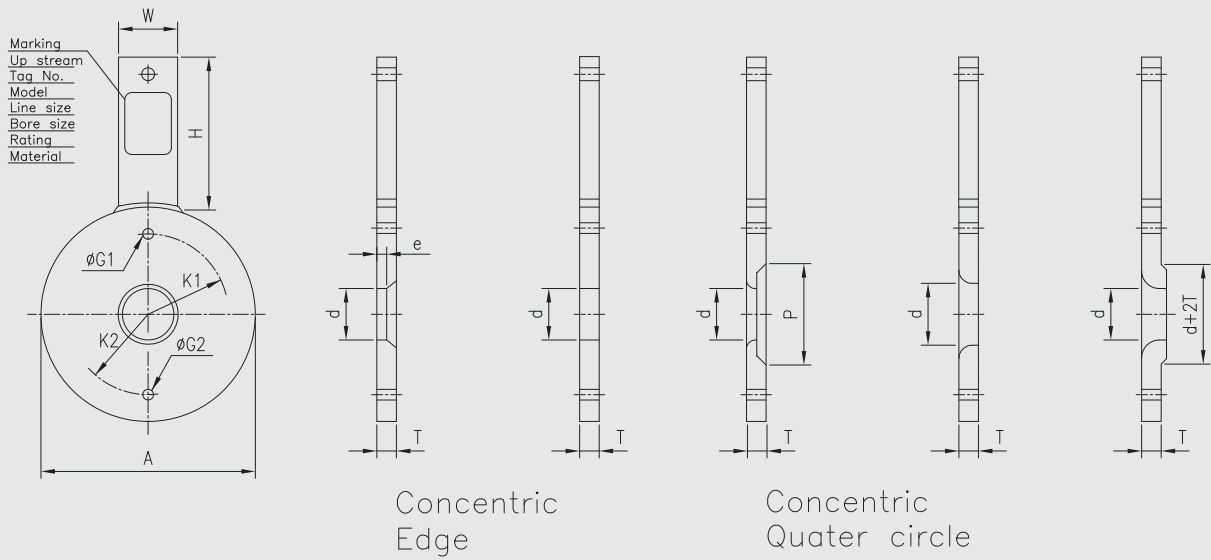

* d, K1, K2, G1, G2 : Refer to Specification Sheet

unit : mm

Nominal Dia	Plate O.D.A						Plate THK' T	Edge e	Handle	
	150 Lb	300 Lb	600 Lb	900 Lb	1,500 Lb	2,500 Lb			W	H
1/2B	47.8	53.8	53.8	63.6	63.6	69.9	3.0	—	25	100
3/4B	57.3	66.7	66.7	69.9	69.9	76.3	3.0	—	25	100
1B	66.5	73.0	73.0	79.4	79.4	85.8	3.0	0.5	25	100
1-1/2B	85.8	95.3	95.3	98.6	98.6	117.5	3.0	0.5	25	100
2B	104.6	111.1	111.1	142.8	142.8	146.1	3.0	0.5	25	100
2-1/2B	123.6	130.4	130.4	165.1	165.1	168.3	3.0	0.5	25	100
3B	136.6	149.1	149.1	168.3	174.6	196.9	3.0	1.0	25	100
4B	174.6	181.0	193.7	206.4	209.6	235.0	3.0	1.0	38	100
5B	197.0	216.0	241.5	247.7	260.4	279.5	3.0	1.5	38	130
6B	222.5	250.7	266.7	288.9	282.6	317.5	3.0	1.5	38	130
8B	279.5	308.0	320.7	358.8	352.4	387.4	3.0	1.5	38	130
10B	339.8	361.9	400.1	435.0	435.0	476.5	6.0	—	38	160
12B	409.8	422.3	457.3	498.5	520.7	549.5	6.0	—	38	160
14B	450.6	485.8	492.2	520.0	577.9	—	6.0	—	38	160
16B	514.1	539.8	565.2	574.7	641.4	—	6.0	—	38	160
18B	549.4	597.0	612.8	637.9	704.9	—	9.0	—	38	160
20B	606.4	654.1	682.6	698.5	755.7	—	9.0	—	38	160
22B	660.5	704.9	733.5	—	—	—	9.0	—	38	160
24B	617.8	774.7	790.6	838.2	901.7	—	9.0	—	38	160

Concentric orifice plate

Simple-structured with high precision, this orifice plate can be easily mounted and dismantled. In strict conformance with applicable standards, it is precisely finished to have required shape, size, surface, roughness and flatness. For differential pressure measurement, it is combined with flange taps, vena contract taps or corner taps.

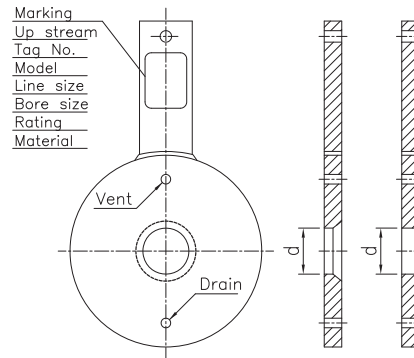

Quadrant edge orifice plate

The inlet edge of the bore of this orifice plate is rounded with a radius of a quarter circle. This orifice plate is principally used for measuring flow rates of low Reynolds numbers.

Flange taps or corner taps are used.

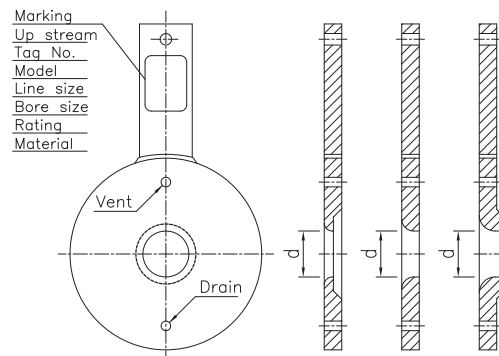

Eccentric orifice plate

For liquids containing solid particles that are liable to settle, or for vapors liable to deposit water condensate, this orifice plate is installed with its eccentric bore bottom flush with the bore bottom of the piping, so that the sedimentation of such inclusions is avoided. Likewise, for gases or vapors, it may be installed with its eccentric bore top flush with the bore top of the piping to avoid the stay of gas or vapor in its vicinity.

Flange taps or vena contract taps are used with.

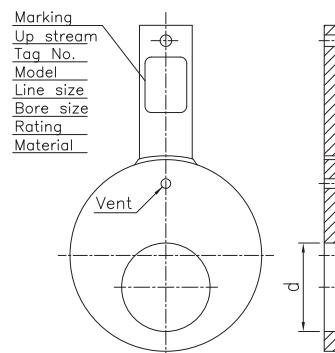

Segmental orifice plate

The vertical section of the bore of this orifice plate is a semicircle to perform the same function as the eccentric orifice plate. Used for the similar purposes. Flange taps or vena contract taps are employed to take out fluid pressures.

