

# Euro gauge

## Test pressure gauge

### Model : P239 series

Spec. sheet no. PD02-06

#### Service intended

P239 test pressure gauges are designed to check the accuracy of pressure instruments. Its use expands to a laboratory instruments for research shops and test labs. External adjustable dial and zero adjustable pointers are available for some models.

It is an excellent choice for the process applications where high accuracy is a must.



#### Nominal diameter

160 and 250 mm

#### Accuracy

±0.25% of full scale

#### Scale range (MPa, kPa, bar)

0 ~ 60 kPa to 0 ~ 100 MPa

#### Working pressure

Steady : Full scale value

#### Working temperature

Ambient : -40 ~ 65°C

Medium : Max. 100°C

#### Temperature effect

Accuracy at temperature above and below the reference temperature (20°C) will be effected by approximately ±0.4% per 10°C of full scale



### Standard features

#### Pressure connection

Stainless steel (316SS)

#### Movement

Brass

#### Element

Stainless steel (316SS)

<100 bar : C type bourdon tube

≥100 bar : Helical type bourdon tube

#### Dial

270° mirror band scale

White aluminium with black graduations

#### Case

160 mm - Stainless steel (304SS)

250 mm - Black painted aluminium, Solid front

#### Pointer

Black painted aluminium alloy

#### Cover

160 mm - Stainless steel (304SS), Bayonet type

250 mm - Black painted aluminium

#### Zero adjustment

Internal (160 mm)

External (250 mm)

#### Window

Safety glass

#### Process connection

3/8", 1/2" PT, NPT and PF

**WISE**<sup>®</sup>

**1. Base model****P239** Test pressure gauge**2. Nominal diameter (mm)**

**6** 160  
**8** 250

**3. Type of mounting**

- A** Bottom connection, direct
- B** Bottom connection, surface, case mounting plate only available with 160 mm
- G** Lower back connection
- L** Lower back connection, surface, case center mounting plate only available with 160 mm
- M** Lower back connection, flush, case center mounting bracket only available with 160 mm
- N** Lower back connection, flush, cover center mounting plate only available with 160 mm
- W** Lower back connection, flush, cover center mounting bracket only available with 160 mm

**4. Accuracy****9** ±0.25% of full scale**5. Process connection**

**D** 3/8"  
**E** 1/2"

**6. Connection type**

**B** PF  
**C** PT  
**D** NPT

**7. Unit**

**H** bar  
**I** MPa  
**J** kPa

**8. Range****XXX** Refer to pressure unit and range table**9. Dial color**

**1** 2 colors  
**2** 3 colors

**10. Option**

- 0** None
- 1** Accessories
- 2** Orifice
- 3** Accessories and orifice

1	2	3	4	5	6	7	8	9	10
P239	8	A	9	E	C	H	XXX	2	0

Sample  
ordering code

## P239 : Type of mounting

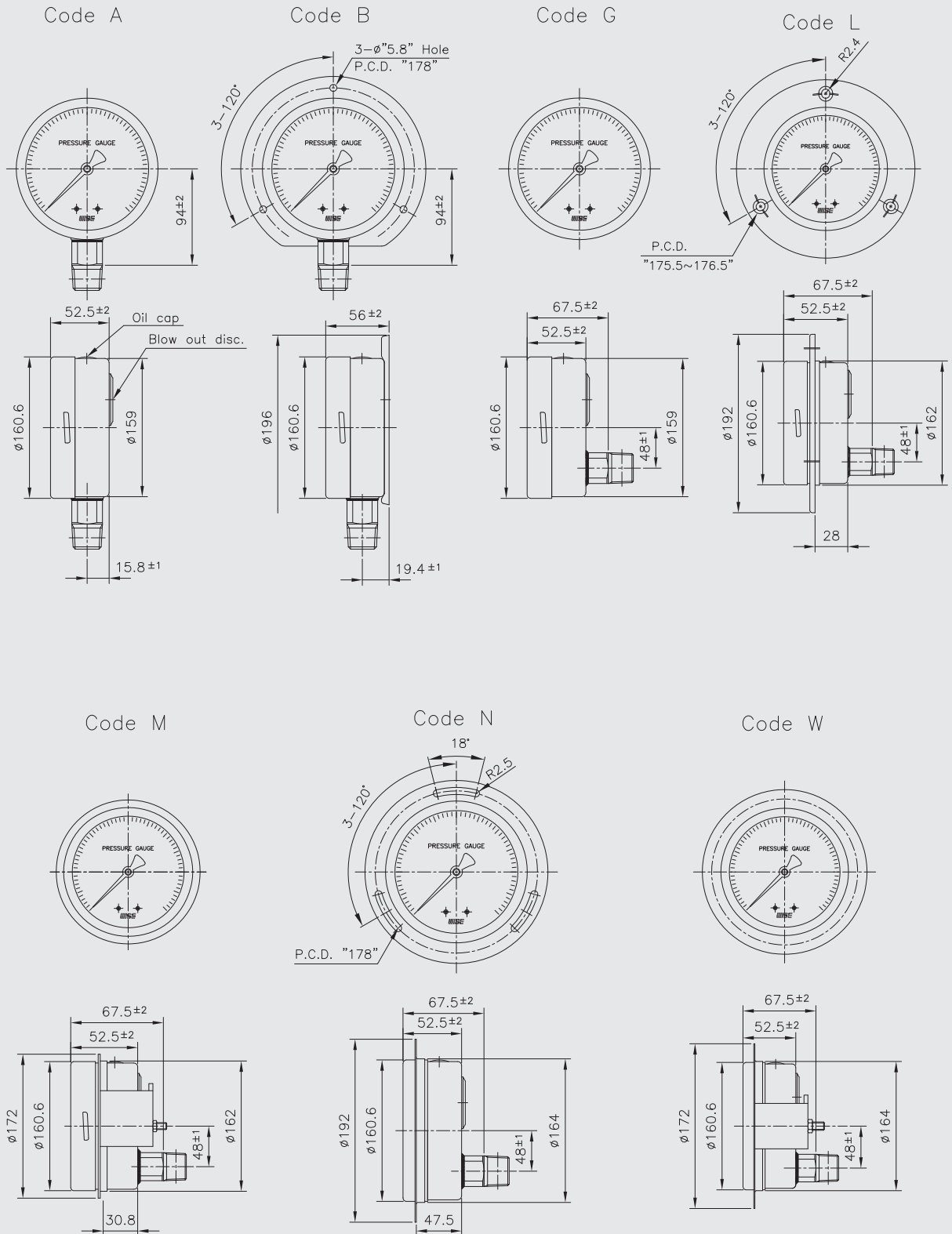

## P239 : Type of mounting (2/2)

Code A

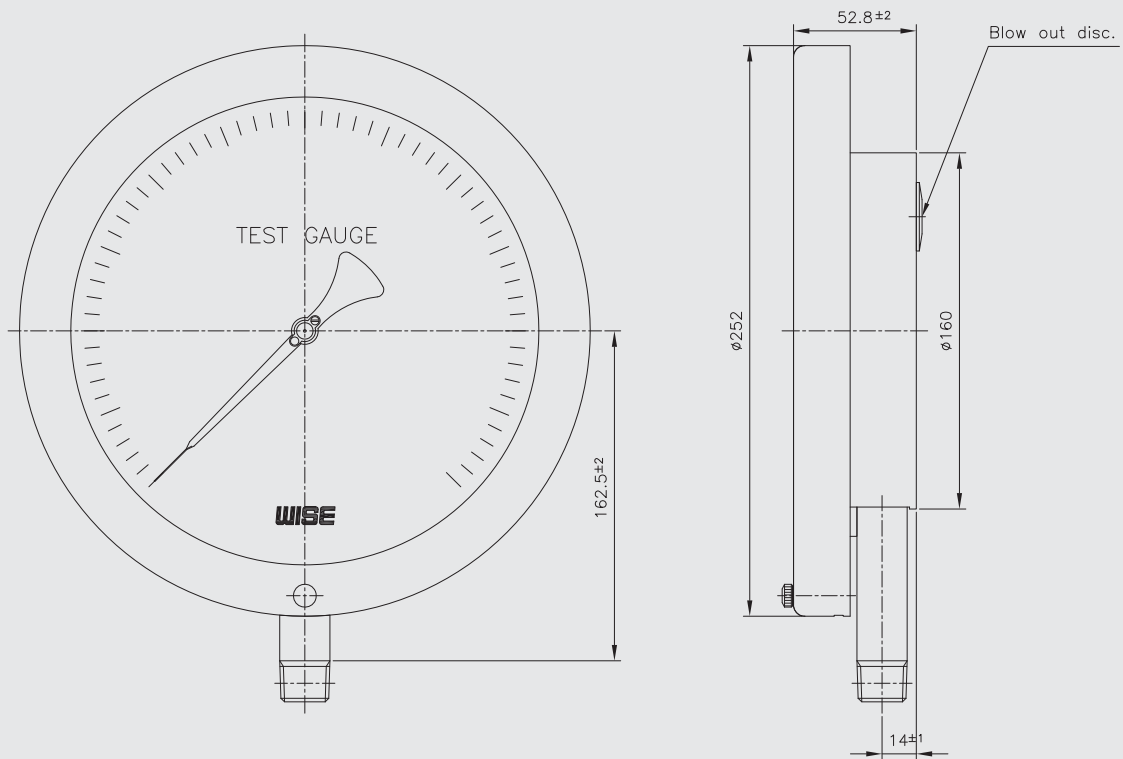

Code G

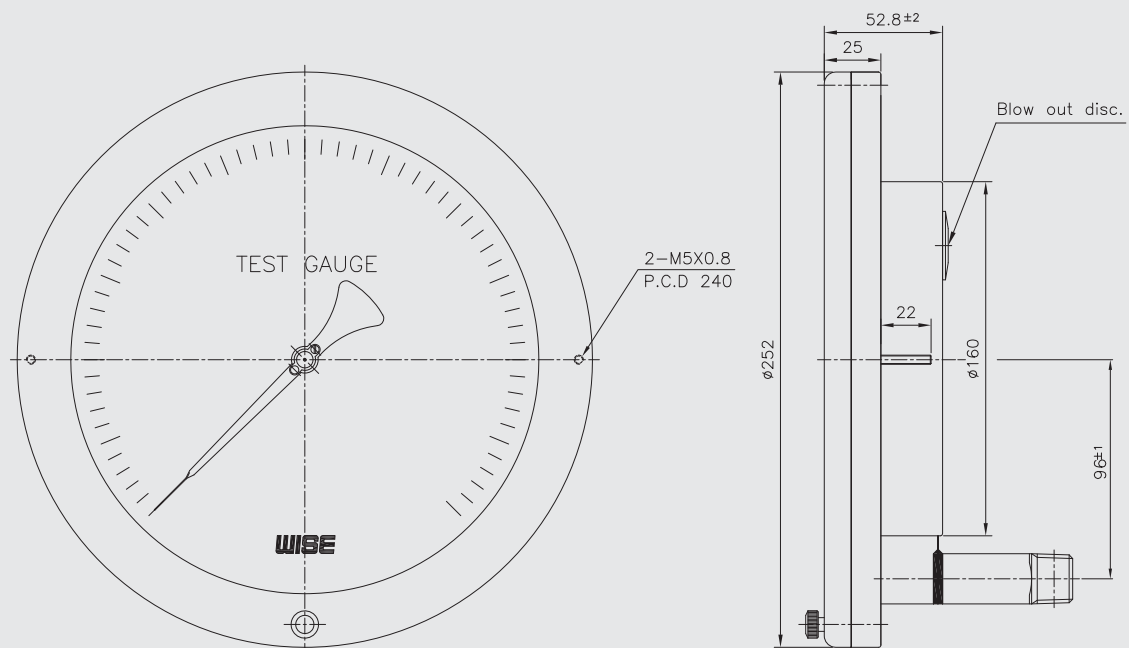

## Pressure unit and range table

Range and code	Unit and code			Nominal diameter
	H : bar	I : MPa	J : kPa	P239
026	-1 ~ 0	-0.1 ~ 0	-100 ~ 0	O
041	0 ~ 1	0 ~ 0.1	0 ~ 100	O
133	0 ~ 1.6	0 ~ 0.16	1 ~ 160	O
042	0 ~ 2	0 ~ 0.2	0 ~ 200	O
134	0 ~ 2.5	0 ~ 0.25	0 ~ 250	O
043	0 ~ 3	0 ~ 0.3	0 ~ 300	O
044	0 ~ 4	0 ~ 0.4	0 ~ 400	O
045	0 ~ 6	0 ~ 0.6	0 ~ 600	O
047	0 ~ 10	0 ~ 1	0 ~ 1,000	O
050	0 ~ 15	0 ~ 1.5	X	O
143	0 ~ 16	0 ~ 1.6	X	O
051	0 ~ 20	0 ~ 2	X	O
052	0 ~ 25	0 ~ 2.5	X	O
054	0 ~ 35	0 ~ 3.5	X	O
151	0 ~ 40	0 ~ 4	X	O
055	0 ~ 50	0 ~ 5	X	O
056	0 ~ 60	0 ~ 6	X	O
057	0 ~ 70	0 ~ 7	X	O
058	0 ~ 100	0 ~ 10	X	O
059	0 ~ 150	0 ~ 15	X	O
060	0 ~ 160	0 ~ 16	X	O
062	0 ~ 250	0 ~ 25	X	O
064	0 ~ 350	0 ~ 35	X	O
065	0 ~ 400	0 ~ 40	X	O
066	0 ~ 500	0 ~ 50	X	O
067	0 ~ 600	0 ~ 60	X	O
068	0 ~ 700	0 ~ 70	X	O
070	0 ~ 1,000	0 ~ 100	X	O

O : Available X : Not available