

Crimped-on-ring case pressure gauge

Model : P255-fully stainless steel construction

Spec. sheet no. PD02-09

Service intended

P255 liquid filled series are suitable for applications with high dynamic pressure loads or vibrations. It is suitable for corrosive environments and gaseous or liquid media that will not obstruct the pressure system. Suitable for machinery industry and parts for various facilities and equipments.



Nominal diameter

63, 80 and 100 mm

Accuracy

63 and 80 mm : $\pm 1.6\%$ of full scale

100 mm : $\pm 1.0\%$ of full scale

Scale range (MPa, kPa, bar)

63 and 80 mm : $-0.1 \sim 0$ to $0 \sim 100$ MPa

100 mm : $-0.1 \sim 0$ to $0 \sim 200$ MPa

Working pressure

Steady : 75% of full scale

Over range protection : 130% of full scale

Working temperature

Ambient : $-40 \sim 65^\circ\text{C}$

$-20 \sim 65^\circ\text{C}$ (With glycerin filling)

$-40 \sim 65^\circ\text{C}$ (With silicone filling)

Fluid : Max. 200°C

Max. 100°C (With glycerin filling)

Max. 100°C (With silicone filling)

Fluid

Dry or glycerin

Degree of protection

EN60529/IEC529/IP67

Temperature effect

Accuracy at temperature above and below the reference temperature (20°C) will be effected by approximately $\pm 0.4\%$ per 10°C of full scale



Standard features

Pressure connection

Stainless steel (316SS)

Window

Safety glass

Element

63 and 80 mm : ≤ 0.3 MPa : C type bourdon tube (316SS)

≥ 0.4 and < 6 MPa : C type bourdon tube (304SS)

≥ 6 MPa : Helical type bourdon tube (316SS)

100 mm : ≤ 0.1 MPa : C type bourdon tube (316SS)

≥ 0.2 and < 10 MPa : C type bourdon tube (304SS)

≥ 10 MPa : Helical type bourdon tube (316SS)

Movement

Stainless steel (316SS)

Dial

White aluminium with black graduations

Pointer

Black painted aluminium alloy

Case and cover

Stainless steel (304SS)

Crimp ring type

Process connection

63 mm : $\frac{1}{4}$ " PT, NPT and PF

80 mm : $\frac{1}{4}$ ", $\frac{3}{8}$ " PT, NPT and PF

100 mm : $\frac{1}{4}$ ", $\frac{3}{8}$ ", $\frac{1}{2}$ " PT, NPT and PF

1. Base model

P255 Crimp-on-ring case pressure gauge

2. Nominal diameter (mm)

- 2** 63
- 3** 80
- 4** 100

3. Type of mounting

- A** Bottom connection, direct
- B** Bottom connection, surface, case mounting plate
- F** Center back connection, only available with diameter 63 mm
- G** Lower back connection, direct
- H** Center back connection, case center mounting plate, only available with diameter 63 mm
- I** Center back connection, cover mounting with bracket only available with diameter 63 mm
- L** Lower back connection, flush, case center mounting plate
- W** Lower back connection, flush, cover mounting bracket

4. Accuracy

- 3** ±1.0% of full scale (Only available with diameter 100 mm)
- 4** ±1.6% of full scale
(Only available with diameter 63 and 80 mm)

5. Process connection

- C** 1/4"
- D** 3/8"
- E** 1/2"
- P** 7/16" UNF

6. Connection type

- B** PF
- C** PT
- D** NPT
- F** BSPT
- G** BSP
- P** Other

7. Unit

- X** Refer to pressure unit and range table

8. Range

XXX Refer to pressure unit and range table

9. Pressure connection material and dial color

- 3** 316SS and 2 colors
- 7** 316SS and 3 colors

10. Option

- 0** Dry
- 8** Silicone filling
- 9** Glycerin filling

1	2	3	4	5	6	7	8	9	10
P255	2	A	4	C	D	X	XXX	3	9

Sample
ordering code

P255 : Type of mounting (1/2)

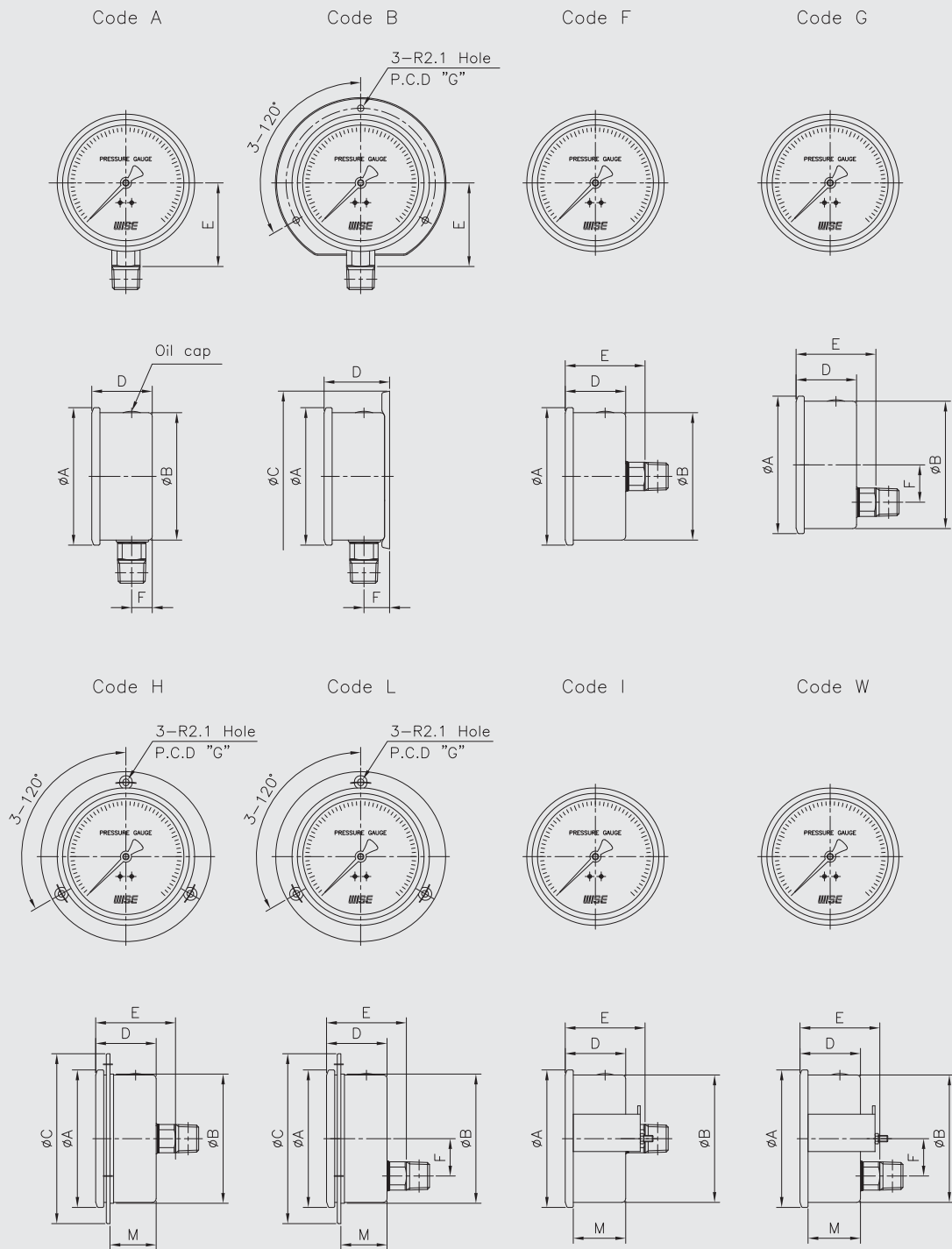

Dimensions (mm)

Dial size	Available code	A	B	C	D ± 2	E ± 2	F ± 1	M	G
63	A	67.8	62		34	41.7	11		
	B	67.8		85	37	41.7	15		74~75
	F	67.8	62		34	45			
	G	67.8	62		34	45	13		
	H	67.8	64.5	92	34	45		22	77~78
	L	67.8	64.5	92	34	45	13	22	77~78
	I	67.8	62		34	45		26.5	
	W	67.8	62		34	45	13	26.5	

P255 : Type of mounting (2/2)

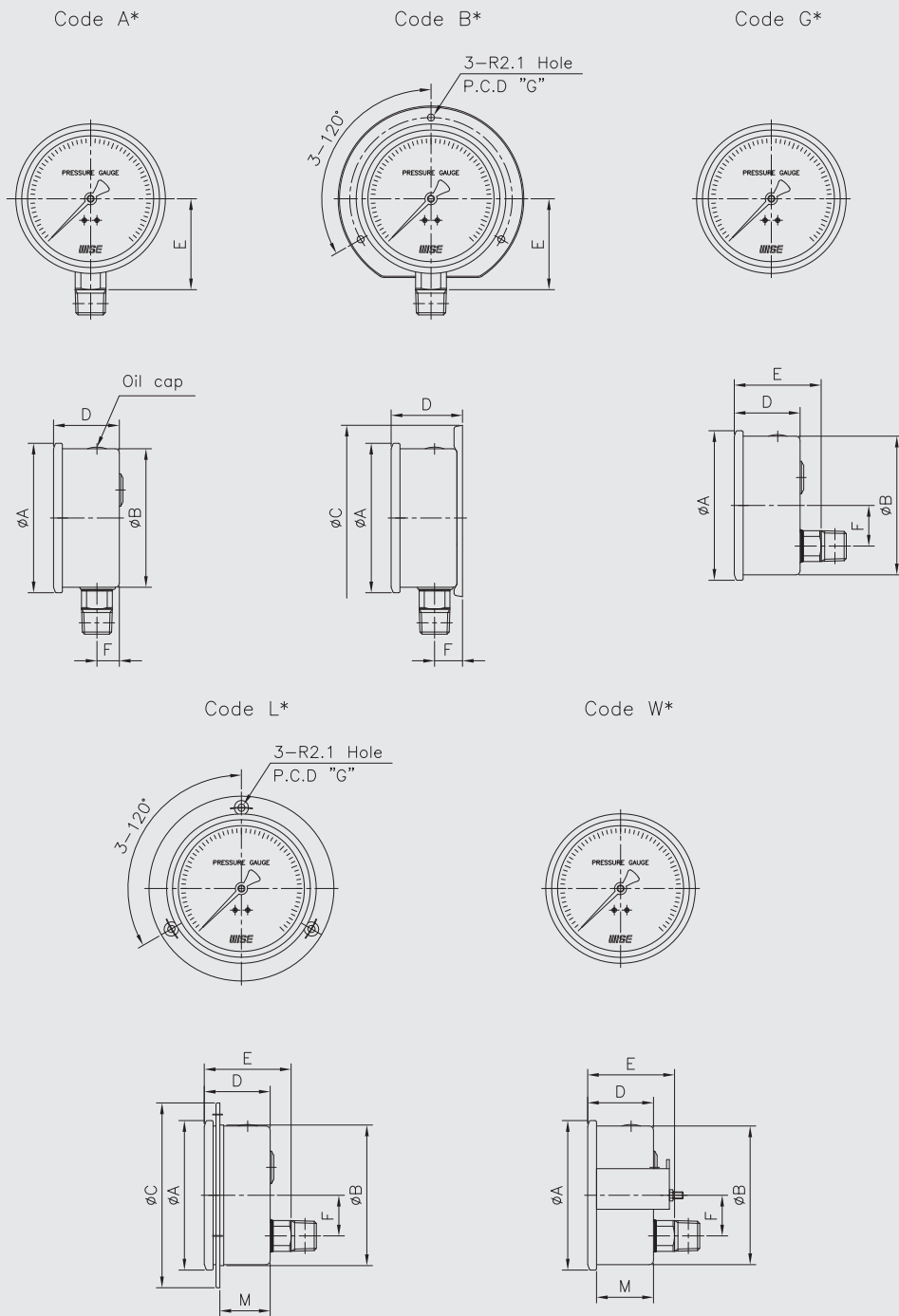

Dimensions (mm)

Dial size	Available code	A	B	C	D ± 2	E ± 2	F ± 1	M	G
80	A*	84.8	78.5		36	50.5	12		
	B*	84.8		108	39.5	50.5	15.5		95
	G*	84.8	78.5		36	50	22		
	L*	84.8	80.8	112	36	50	22	26.8	94.5~95.5
	W*	84.8	78.5		36	50	22	31.5	
100	A*	106.8	99		47	65	16		
	B*	106.8		133	51	65	19.4		116
	G*	106.8	99		47	62	29		
	L*	106.8	100.4	132	47	62	29	36	115~116
	W*	106.8	99		47	62	29	40.5	

Pressure unit and range table

Range and code	Unit and code			63 mm	80 mm	100 mm
	H : bar	I : MPa	J : kPa			
026	-1 ~ 0	-0.1 ~ 0	-100 ~ 0	O	O	O
040	0 ~ 0.5	0 ~ 0.05	0 ~ 50	X	X	O
041	0 ~ 1	0 ~ 0.1	0 ~ 100	O	O	O
042	0 ~ 2	0 ~ 0.2	0 ~ 200	O	O	O
043	0 ~ 3	0 ~ 0.3	0 ~ 300	O	O	O
044	0 ~ 4	0 ~ 0.4	0 ~ 400	O	O	O
045	0 ~ 6	0 ~ 0.6	0 ~ 600	O	O	O
047	0 ~ 10	0 ~ 1	0 ~ 1,000	O	O	O
050	0 ~ 15	0 ~ 1.5	X	O	O	O
051	0 ~ 20	0 ~ 2	X	O	O	O
052	0 ~ 25	0 ~ 2.5	X	O	O	O
054	0 ~ 35	0 ~ 3.5	X	O	O	O
055	0 ~ 50	0 ~ 5	X	O	O	O
057	0 ~ 70	0 ~ 7	X	O	O	O
058	0 ~ 100	0 ~ 10	X	O	O	O
059	0 ~ 150	0 ~ 15	X	O	O	O
062	0 ~ 250	0 ~ 25	X	O	O	O
064	0 ~ 350	0 ~ 35	X	O	O	O
066	0 ~ 500	0 ~ 50	X	O	O	O
067	0 ~ 600	0 ~ 60	X	O	O	O
068	0 ~ 700	0 ~ 70	X	O	O	O
070	0 ~ 1,000	0 ~ 100	X	O	O	O
074	0 ~ 1,600	0 ~ 160	X	X	X	O
075	0 ~ 2,000	0 ~ 200	X	X	X	O
027	-1 ~ 1	-0.1 ~ 0.1	-100 ~ 100	O	O	O
028	-1 ~ 2	-0.1 ~ 0.2	-100 ~ 200	O	O	O
029	-1 ~ 3	-0.1 ~ 0.3	-100 ~ 300	O	O	O
030	-1 ~ 4	-0.1 ~ 0.4	-100 ~ 400	O	O	O
031	-1 ~ 6	-0.1 ~ 0.6	-100 ~ 600	O	O	O
032	-1 ~ 10	-0.1 ~ 1	-100 ~ 1,000	O	O	O
033	-1 ~ 15	-0.1 ~ 1.5	-100 ~ 1.5 MPa	O	O	O
034	-1 ~ 20	-0.1 ~ 2	-100 ~ 2 MPa	O	O	O

O : Available X : Not available