

Euro gauge

Safety pattern type pressure gauge

Model : P257 series

Spec. sheet no. PD02-10

Service intended

P257 series are made with a solid plate wall and a blow-out back. Its stainless steel case and cover have a good appearance. It has the excellent proof against corrosion and chemical attack.



Nominal diameter

63, 100 and 160 mm

Accuracy

P2572 (63 mm) : $\pm 1.6\%$ of full scale
P2574 (100 mm) and P2576 (160 mm) : $\pm 0.5\%$ of full scale
 $\pm 1.0\%$ of full scale

Scale range (MPa, kPa, bar)

63 mm : -0.1 ~ 0 to 0 ~ 100 MPa
100 and 160 mm : -0.1 ~ 0 to 0 ~ 200 MPa

Working pressure

Steady : 75% of full scale (63 mm)
100% of full scale (100 and 160 mm)
Over range protection : 130% of full scale

Working temperature

Ambient : -40 ~ 65°C
-20 ~ 65°C (With glycerin filling)
-40 ~ 65°C (With silicone filling)
Fluid : Max. 200°C
Max. 100°C (With glycerin filling)
Max. 100°C (With silicone filling)

Degree of protection

EN60529/IEC529/IP67

Temperature effect

Accuracy at temperature above and below the reference temperature (20°C) will be effected by approximately $\pm 0.4\%$ per 10°C of full scale



Standard features

Pressure connection

Stainless steel (316SS)

Element

Stainless steel (316SS)
63 mm : <6 MPa : C type bourdon tube
≥6 MPa : Helical type bourdon tube
100 and 160 mm : <10 MPa : C type bourdon tube
≥10 MPa : Helical type bourdon tube

Case

Stainless steel (304SS)

Cover

Stainless steel (304SS)
Bayonet type

Blowout protection

Solid front
Blow-out back

Window

Laminated safety glass

Movement

Stainless steel

Dial

White aluminium with black graduations

Pointer

Black painted aluminium alloy

Process connection

63 mm : 1/8", 1/4" PT, NPT and PF
100 and 160 mm : 1/4", 1/2", 3/8" PT, NPT and PF

Optional

Zero adjustable pointer
(Only available with diameter 100 and 160 mm)
Zero adjustment (External) : 100 and 160 mm
Pressure connection and element : Monel

WISE[®]

1. Base model

P257 Safety pattern type pressure gauge

2. Nominal diameter (mm)

- 2** 63
- 4** 100
- 6** 160

3. Type of mounting

- A** Bottom connection, direct
- C** Bottom connection, surface, cover mounting plate
- G** Lower back connection, direct, not available with diameter 160 mm
- M** Lower back connection, flush, case center mounting bracket, not available with diameter 160 mm
- N** Lower back connection, flush, cover mounting plate, not available with diameter 160 mm

4. Accuracy

- 2** ±0.5% of full scale. not available with diameter 63 mm
- 3** ±1.0% of full scale. not available with diameter 63 mm
- 4** ±1.6% of full scale. only available with diameter 63 mm

5. Process connection

- B** 1/8" only available with diameter 63 mm
- C** 1/4"
- D** 3/8" not available with diameter 63 mm
- E** 1/2" not available with diameter 63 mm

6. Connection type

- B** PF
- C** PT
- D** NPT
- F** BSPT
- G** BSP(G)

7. Unit

- H** bar
- I** MPa
- J** kPa
- Z** Other

8. Range

XXX Refer to pressure unit and range table

9. Dial color

- 3** 316SS and 2 colors
- 4** 316L SS and 2 colors
- 7** 316SS and 3 colors
- 8** 316L SS and 3 colors
- Z** Monel

10. Option

- 0** None
- 1** Accessories
- 8** Silicone filling
- 9** Glycerin filling

1	2	3	4	5	6	7	8	9	10
P257	4	A	3	C	D	H	XXX	3	9

Sample
ordering code

P257 : Type of mounting

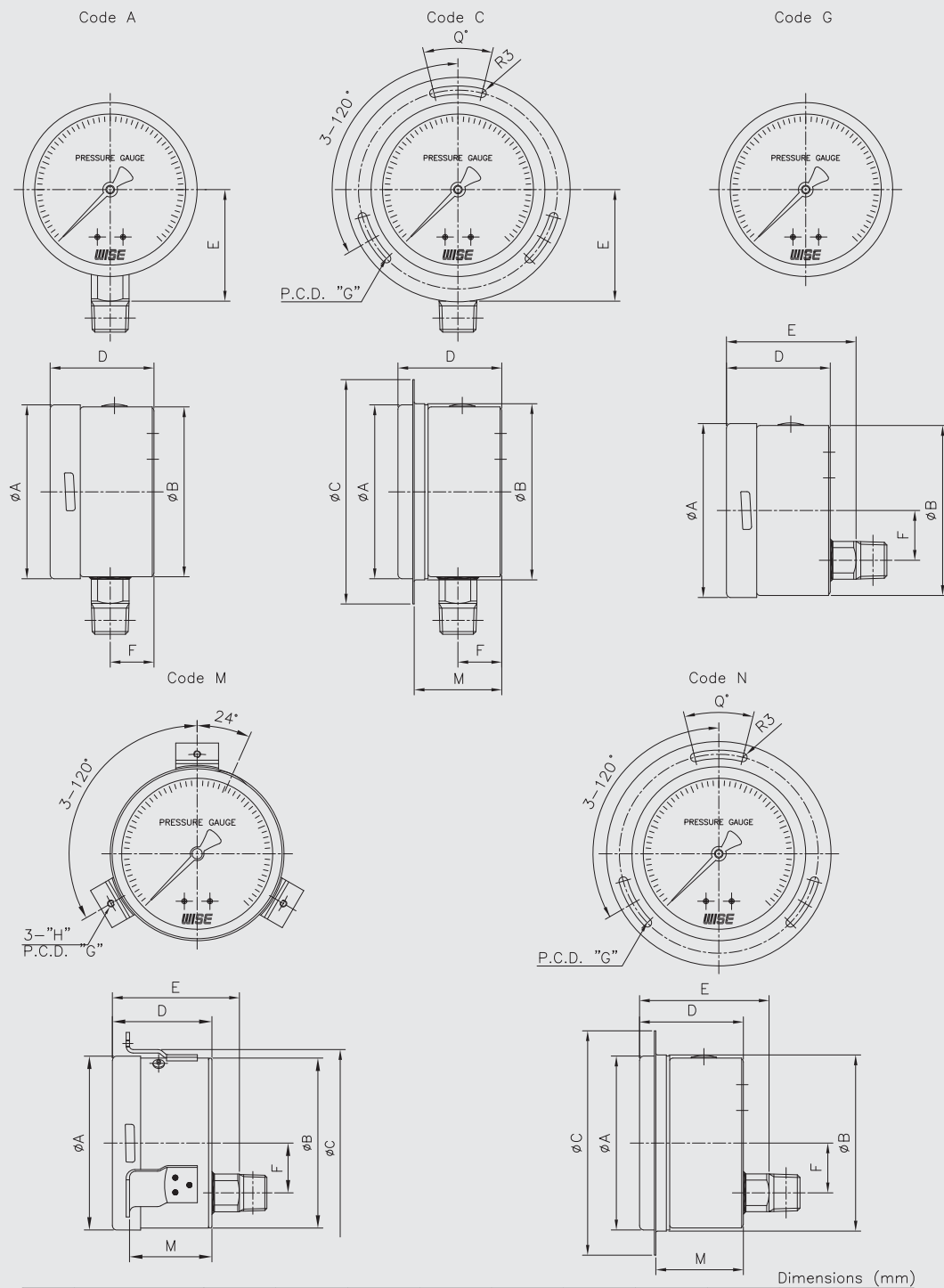

Dimensions (mm)

Dial size	Available code	A	B	C	D±2	E±2	F±1	G	H	M	Q
63	A	64	62		42.5	41.8	17.2				
	G	64	62		42.5	51	16.7				
	M	64	62	68	42.5	51	16.7	75	M3X0.5	34	
100	A	101.3	99		59	65	25.5				
	C	101.3	103.1	130.5	59	65	25.5	116		45	28
	G	101.3	99		59	75.5	29				
	N	101.3	103.1	130.5	59	75.5	29	116		45	28
160	M	101.3	99	108	59	75.5	29	116	M4X0.7	48	
	A	160.8	159.6		62	90	25.6				
	C	160.8	164	196	62	90	25.6	178		57	18

Pressure unit and range table

Range and code	Unit and code			63 mm	100 mm	160 mm
	H : bar	I : MPa	J : kPa			
026	-1 ~ 0	-0.1 ~ 0	-100 ~ 0	O	O	O
123	0 ~ 0.4	0 ~ 0.04	0 ~ 40	X	O	O
040	0 ~ 0.5	0 ~ 0.05	0 ~ 50	X	O	O
041	0 ~ 1	0 ~ 0.1	0 ~ 100	O	O	O
133	0 ~ 1.6	0 ~ 0.16	0 ~ 160	X	O	O
042	0 ~ 2	0 ~ 0.2	0 ~ 200	O	O	O
134	0 ~ 2.5	0 ~ 0.25	0 ~ 250	X	O	O
043	0 ~ 3	0 ~ 0.3	0 ~ 300	O	O	O
044	0 ~ 4	0 ~ 0.4	0 ~ 400	O	O	O
045	0 ~ 6	0 ~ 0.6	0 ~ 600	O	O	O
047	0 ~ 10	0 ~ 1	X	O	O	O
050	0 ~ 15	0 ~ 1.5	X	O	O	O
143	0 ~ 16	0 ~ 1.6	X	O	O	O
051	0 ~ 20	0 ~ 2	X	O	O	O
052	0 ~ 25	0 ~ 2.5	X	O	O	O
054	0 ~ 35	0 ~ 3.5	X	O	O	O
151	0 ~ 40	0 ~ 4	X	O	O	O
055	0 ~ 50	0 ~ 5	X	O	O	O
056	0 ~ 60	0 ~ 6	X	O	O	O
057	0 ~ 70	0 ~ 7	X	O	O	O
058	0 ~ 100	0 ~ 10	X	O	O	O
059	0 ~ 150	0 ~ 15	X	O	O	O
060	0 ~ 160	0 ~ 16	X	O	O	O
062	0 ~ 250	0 ~ 25	X	O	O	O
064	0 ~ 350	0 ~ 35	X	O	O	O
065	0 ~ 400	0 ~ 40	X	O	O	O
066	0 ~ 500	0 ~ 50	X	O	O	O
067	0 ~ 600	0 ~ 60	X	O	O	O
068	0 ~ 700	0 ~ 70	X	O	O	O
070	0 ~ 1,000	0 ~ 100	X	O	O	O
074	0 ~ 1,600	0 ~ 160	X	X	O	O
075	0 ~ 2,000	0 ~ 200	X	X	O	O
006	-1 ~ 0.6	-0.1 ~ 0.06	-100 ~ 60	X	O	O
027	-1 ~ 1	-0.1 ~ 0.1	-100 ~ 100	O	O	O
007	-1 ~ 1.5	-0.1 ~ 0.15	-100 ~ 150	X	O	O
028	-1 ~ 2	-0.1 ~ 0.2	-100 ~ 200	O	O	O
029	-1 ~ 3	-0.1 ~ 0.3	-100 ~ 300	O	O	O
030	-1 ~ 4	-0.1 ~ 0.4	-100 ~ 400	O	O	O
010	-1 ~ 5	-0.1 ~ 0.5	-100 ~ 500	O	O	O
031	-1 ~ 6	-0.1 ~ 0.6	-100 ~ 600	O	O	O
014	-1 ~ 9	-0.1 ~ 0.9	-100 ~ 900	O	O	O
032	-1 ~ 10	-0.1 ~ 1	-100 ~ 1,000	O	O	O
033	-1 ~ 15	-0.1 ~ 1.5	-100 ~ 1.5 MPa	O	O	O
034	-1 ~ 20	-0.1 ~ 2	-100 ~ 2 MPa	O	O	O
017	-1 ~ 24	-0.1 ~ 2.4	-100 ~ 2.4 MPa	O	O	O
035	-1 ~ 25	-0.1 ~ 2.5	-100 ~ 2.5 MPa	O	O	O

O : Available X : Not available