

Euro gauge

Inductive contact type pressure gauge

Model: P500 series

Spec. sheet no. PD05-01

Service intended

P500 series are designed for a local reading of measured pressure and equipped with the inductive contact block which allows all the combinations of contacts to be used. The contact block is mounted on the dial. The window is fitted with a knob for external adjustment of the setpoints.



Nominal diameter

100 and 160 mm

Accuracy

±1.0% of full scale for pressure indication

Scale range (MPa, kPa, bar)

-0.1 ~ 0 to 0 ~ 200 MPa

Working pressure

Steady : 100% of full scale

Over range protection : 130% of full scale

Working temperature

Ambient : -40 ~ 65°C

-40 ~ 65°C (With silicone filling)

Fluid : Max. 200°C

Max. 100°C (With silicone filling)



Degree of protection

EN60529/IEC529/IP67

Temperature effect

Accuracy at temperature above and below the reference temperature (20°C) will be effected by approximately ±0.4% per 10°C of full scale

Standard features

Pressure connection

Stainless steel (316SS)

Element

Stainless steel (316SS)

<10 MPa : C type bourdon tube

≥10 MPa : Helical type bourdon tube

Case

Stainless steel (304SS)

Bezel ring

Stainless steel (304SS)

Bayonet type

Window

Safety glass : 100 mm only

Polycarbonate : 100 and 160 mm

Movement

Stainless steel

Dial

White aluminium with black graduations

Pointer

Black painted aluminium alloy

Process connection

3/8", 1/2" PT, NPT and PF

Conduit connection

M20 x 1.5

Optional

Damping movement

Approval

Explosion proof (Ex ia IIC T6-KOSHA)

Tamb= -20 ~ 56°C

WISE[®]

1. Base model

P500 Inductive contact type pressure gauge

2. Nominal diameter and window material

- 4** 100 mm and safety glass
- 5** 100 mm and polycarbonate window
- 6** 160 mm and polycarbonate window

3. Type of mounting

- A** Bottom connection, direct
- B** Bottom connection, surface, case mounting plate
- G** Lower back connection, direct (Only available with diameter 100 mm)
- N** Lower back connection, flush, cover mounting plate (Only available with diameter 100 mm)

4. Contact function

- 1** High alarm, Normal open contact
- 2** High and low alarm
- 3** Low alarm, Normal close contact
- 4** High and hi/high alarm
- 5** Low and lo/low alarm
- 6** Failsafe high and low alarm

5. Process connection

- D** 3/8"
- E** 1/2"

6. Connection type

- B** PF
- C** PT
- D** NPT
- F** BSPT
- G** BSP
- Z** Other

7. Unit

- H** bar
- I** MPa
- J** kPa

8. Range

XXX Refer to pressure unit and range table

9. Pressure connection material and dial color

- 3** 316SS and 2 colors
- 4** 316L SS and 2 colors
- 7** 316SS and 3 colors
- 8** 316L SS and 3 colors
- Z** Monel

10. Option

- 0** None
- 1** Amplifier (AC 230 V)

1	2	3	4	5	6	7	8	9	10
P500	4	A	4	D	B	J	XXX	3	0

Sample
ordering code

P500 : Type of mounting (Polycarbonate window 1/2)

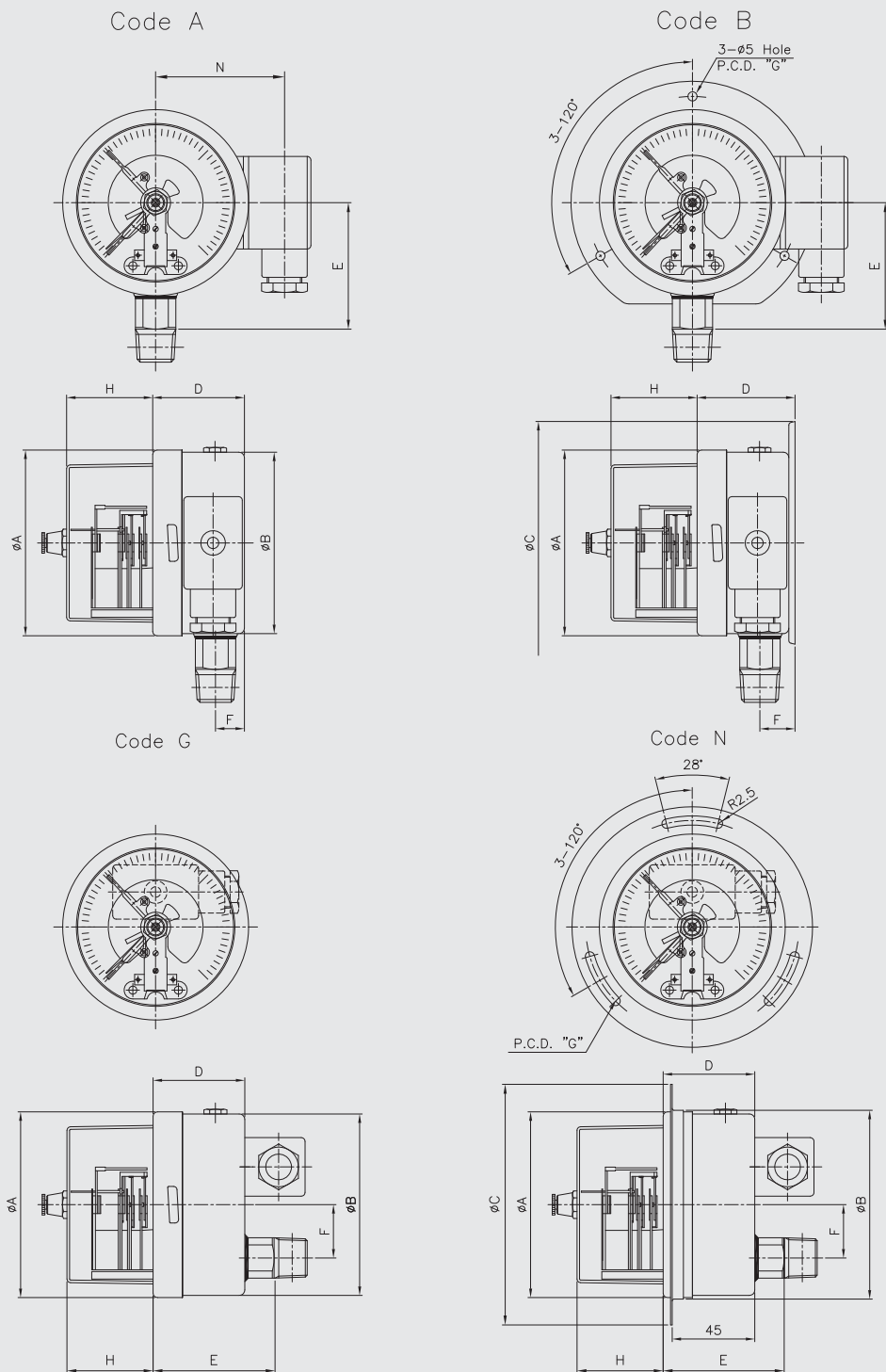

Dimensions (mm)

Dial size	Available code	A	B	C	D±2	E±2	F±1	G	H	N
100	A	101.3	99		50	65	16		34.5	75
	B	101.3		133	54.4	65	19.4	116	34.5	
	G	101.3	99		50	65	29		34.5	
	N	101.3	103.1	131	50	65	29	116	34.5	
160	A	160.6	159		52.5	94	15.8		34	105
	B	160.6		196	56	94	19.4	178	34	105

P500 : Type of mounting (Safety glass window 2/2)

Code A (Only 100mm)

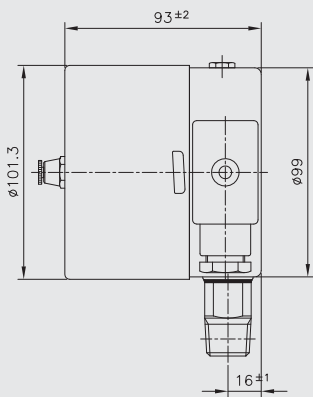
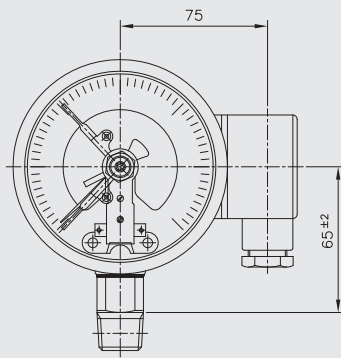

Code B

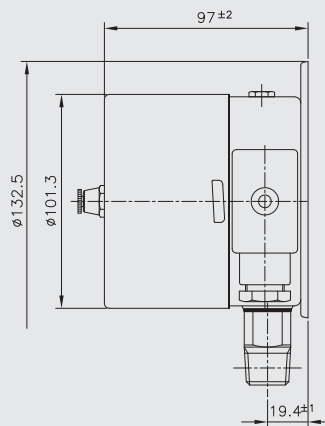
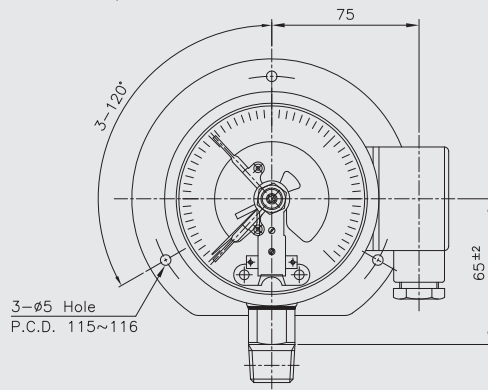

Code G

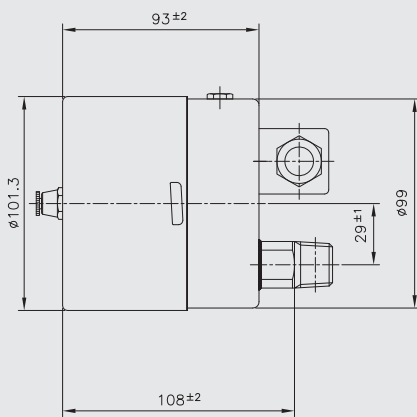
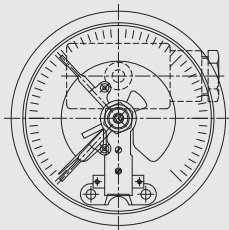

Code N

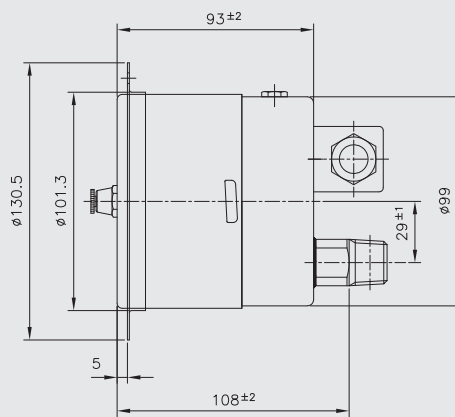
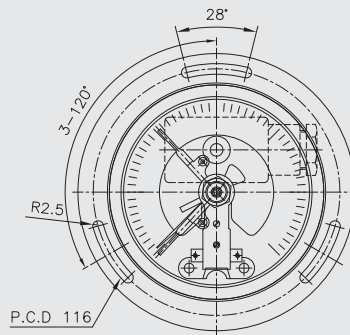

Contact function table

Code	Wiring scheme	Contact function		Wiebrock code no.	Slot sensor	
		1 st contact	2 nd contact			
Single contact						
1	Control vane inside the slot sensor - Contact make (Normal open)				I-1	SJ2N for 100 mm SJ3.5N for 160 mm
3	Control vane out of the slot sensor - Contact break (Normal close)				I-2	SJ2N for 100 mm SJ3.5N for 160 mm
Double contact						
4	1 st and 2 nd Control vane inside the slot sensor - 1 st and 2 nd Contact make	1 st 2 nd 			I-11	SJ2N for 100 mm SJ3.5N for 160 mm
6	1 st Control vane inside and 2 nd control vane out of the slot sensor - 1 st Contact make 2 nd Contact break	1 st 2 nd 			I-12	SJ2N for 100 mm SJ3.5N for 160 mm
2	1 st Control vane out of the vane and 2 nd control vane inside of the vane - 1 st Contact break 2 nd Contact make	1 st 2 nd 			I-21	SJ2N for 100 mm SJ3.5N for 160 mm
5	1 st and 2 nd Control vane out of the slot sensor - 1 st and 2 nd Contact break	 			I-22	SJ2N for 100 mm SJ3.5N for 160 mm

Inductive alarm sensor model P500 series

Service intended

WISE inductive contacts are certified for use in hazardous areas of zone 0.

power supply must be made by means of a power source certified intrinsically safe such as pepper and fucus model KFA6-SR2-Ex1.W

Inductive contact are also recommended for critical non-hazardous applications where an utmost of failsafe heavy duty operation is required.

In combination with liquid filled instruments these contacts are particularly suited for process control circuits in the chemical and petroleum industry.

Operating principle

At the heart of the WISE inductive contact system is a non-contact sensor attached to an pressure gauge. Both sensor and gauge are adjustable over the full length of the scale. Contact actuation is achieved by means of a Control vane linked to the pointer of the gauge.

The control vane affects the electric field of the sensor when the instruments pointer overlaps with the contacts indicator.

Contact actuation is made without any mechanical force that would affect accuracy of the gauge.

The scheme below reflects the operating principle in comparison with conventional mechanical contacts :

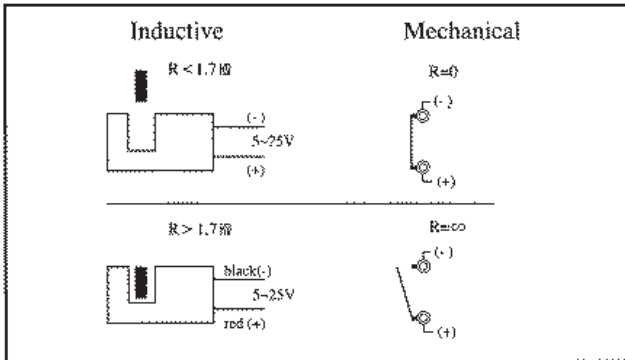

Dimensions of the basic instrument and provisions for contacts adjustment are identical to contacts of model P500.

Operating temperature: -25°C... +70°C

Used sensor (slot-type initiator) :

Type SJ of the company Pepper and Fuchs,

EC-type-examination certificate PTB 99 ATEX 2219 X

Advantage of the WISE inductive system

- Long service life by means of non-contact sensor
- Very little effect on gauge accuracy
- No reduced rating with liquid filled gauges
- Fully suitable in corrosive or hazardous atmosphere
- Ex-approved for service in hazardous area of zone 1 or 2

Components of the WISE inductive contact system

Operation of the inductive contact system requires an appropriate electronic power supply and control unit.

The Safety Barrier consists of

- Line transformer
- Amplifier circuit
- Relay to switch external circuit

The isolated line transformer provides for power supply whereas the amplifier conditions the signal of the inductive sensor to energise the output relay.

Available are two versions of control units

- Ex-approved intrinsic safety
- Standard for non-intrinsically safe version (optional)

Safety barrier for inductive contacts
Ex-certified versions
Safety barrier model KFA6-SR2-Ex1.W

- Intended for instruments having one inductive contact incorporated
- Alarm circuit certified intrinsically safe [EEx id] IIC to EN 50 227 and NAMUR
- Provides 1 SPDT relay output contact
- LED indicating circuit status (green), relay output (yellow) and lead breakage (red)

Note

Directions of action adjustable by sliding switch S1 :
 Open circuit causes alarm : Switch S1 in position I
 Closed circuit causes alarm : Switch S1 in position II

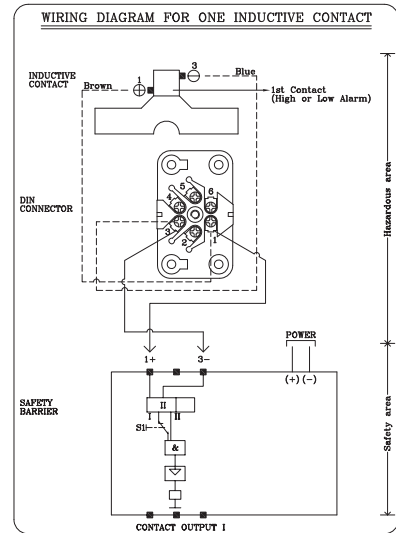

SAFETY BARRIER MODEL	Contact Output I (High or Low Alarm)	POWER
KFA5-SR2-Ex1.W(115V, AC)	7(COMMON) 8(OPEN) 9(CLOSE)	14(+) 15(-)
KFA6-SR2-Ex1.W(230V, AC)		
KFD2-SR2-Ex1.W(24V,DC)		

Safety barrier model KFA6-SR2-Ex2.W

- Intended for 1 instrument having two or two instruments having one each contact incorporated
- Alarm circuit certified intrinsically safe [EEx id] IIC to EN 50 227 and NAMUR
- Provides 2 SPDT relay output contacts
- LED indicating circuit status (green), 2 x relay output (yellow) and 2 x lead breakage (red)
- Case surface-mounting type from B

Note

Directions of action adjustable by sliding switch S1 and S2 :
 Open circuit causes alarm : Switch S1 and S2 in position I
 Closed circuit causes alarm : Switch S1 and S2 in position II

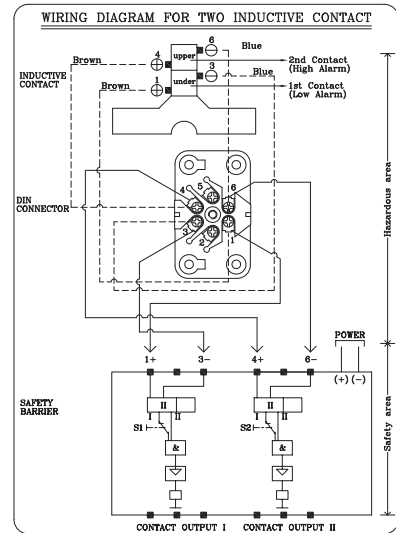

SAFETY BARRIER MODEL	Contact Output I (Low Alarm)	Contact Output II (High Alarm)	POWER
KFA5-SR2-Ex2.W(115V, AC)	7(COMMON) 8(OPEN) 9(CLOSE)	10(COMMON) 11(OPEN) 12(CLOSE)	14(+) 15(-)
KFA6-SR2-Ex2.W(230V, AC)			
KFD2-SR2-Ex2.W(24V,DC)			

Dimensions of safety barrier for inductive contact

Model : KFA6-SR2-Ex1.W

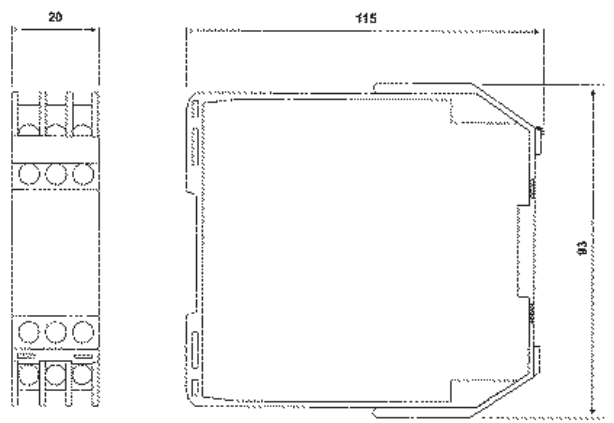

From A

Model : KFA6-SR2-Ex2.W

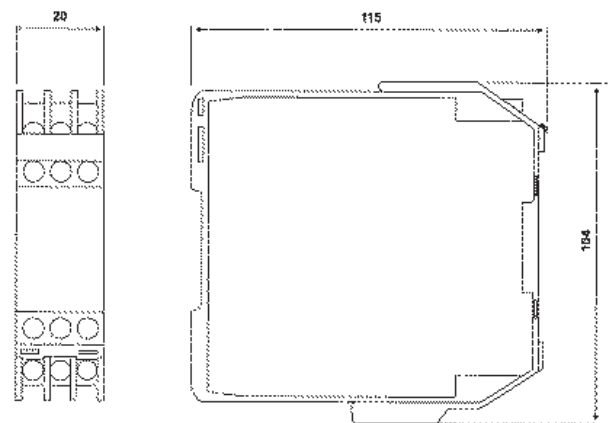

From B

Specifications for safety barrier	Model KFA6-SR2-Ex1.W	Model KFA6-SR2-Ex2.W
Power supply		
Line voltage 1)	AC 230 V ±0%, 45...65 Hz	AC 230 V±0%, 45...65 Hz
Consumption	1 VA	1.3 VA
Input		
No.of contacts	1	2
Voltage (reactive)	DC 8 V	DC 8 V
Maximum current	8 mA	8 mA
Contact actuation	$1.2 \text{ mA} \leq I_s \leq 2.1 \text{ mA}$	$1.2 \text{ mA} \leq I_s \leq 2.1 \text{ mA}$
Contact hysteresis	ca. 0.2 mA	ca. 0.2 mA
Control line impedance	100 Ω	100 Ω
Ex-IS data (as PTB-certified)		
Voltage	$U_o \leq \text{DC } 10.6 \text{ V}$	$U_o \leq \text{DC } 10.6 \text{ V}$
Current	$I_o \leq 19.1 \text{ mA}$	$I_o \leq 19.1 \text{ mA}$
Power rating	$P_o \leq 51 \text{ mW}$	$P_o \leq 51 \text{ mW}$
IS-classification	[EEx ia] IIC	[EEx ia] IIC
Ext. capacitance	2.9µF	2.9µF
Ext. inductance	100 mH	100 mH
Output		
Relay contacts	1 SPDT	1 ea. SPDT
Contact rating AC	253 V, 2 A, 500 VA, $\cos\varnothing > 0.7$	253 V, 2 A, 500 VA, $\cos\varnothing > 0.7$
Contact rating DC	4 V, 2 A, ohmic	4 V, 2 A, ohmic
Delay making circuit	Approx. 20 ms	Approx. 20 ms
Delay breaking circuit	Approx. 20 ms	Approx. 20 ms
Max. on-off frequency	10 Hz	10 Hz
Operating conditions		
Min. temperature	-20°C	-20°C
Max. temperature	+60°C	+60°C
Max. humidity	Max. 75%	Max. 75%
Ingress protection	IP 20 (EN 60 529 / IEC529)	IP 20 (EN 60 529 / IEC529)
Enclosure		
Style	Surface mounting	-20°C
Dimensions per drawing	From D, page 11	+60°C
Mounting	Snap-fit on 35 mm x 7.5 mm (EN 50 022) rail. direct mounting feasible	
Weight	Approx. 0.15 kg	Approx. 0.15 kg
Product no.	2014505	2014505

Pressure unit and range table

Range and code	Unit and code			100 mm	160 mm
	H : bar	I : MPa	J : kPa		
026	-1 ~ 0	-0.1 ~ 0	-100 ~ 0	O	O
040	0 ~ 0.5	0 ~ 0.05	0 ~ 50	O	O
041	0 ~ 1	0 ~ 0.1	0 ~ 100	O	O
133	0 ~ 1.6	0 ~ 0.16	0 ~ 160	O	O
042	0 ~ 2	0 ~ 0.2	0 ~ 200	O	O
134	0 ~ 2.5	0 ~ 0.25	0 ~ 250	O	O
043	0 ~ 3	0 ~ 0.3	0 ~ 300	O	O
044	0 ~ 4	0 ~ 0.4	0 ~ 400	O	O
045	0 ~ 6	0 ~ 0.6	0 ~ 600	O	O
047	0 ~ 10	0 ~ 1	0 ~ 1,000	O	O
050	0 ~ 15	0 ~ 1.5	X	O	O
143	0 ~ 16	0 ~ 1.6	X	O	O
051	0 ~ 20	0 ~ 2	X	O	O
052	0 ~ 25	0 ~ 2.5	X	O	O
054	0 ~ 35	0 ~ 3.5	X	O	O
151	0 ~ 40	0 ~ 4	X	O	O
055	0 ~ 50	0 ~ 5	X	O	O
056	0 ~ 60	0 ~ 6	X	O	O
057	0 ~ 70	0 ~ 7	X	O	O
058	0 ~ 100	0 ~ 10	X	O	O
059	0 ~ 150	0 ~ 15	X	O	O
060	0 ~ 160	0 ~ 16	X	O	O
062	0 ~ 250	0 ~ 25	X	O	O
064	0 ~ 350	0 ~ 35	X	O	O
065	0 ~ 400	0 ~ 40	X	O	O
066	0 ~ 500	0 ~ 50	X	O	O
067	0 ~ 600	0 ~ 60	X	O	O
068	0 ~ 700	0 ~ 70	X	O	O
070	0 ~ 1,000	0 ~ 100	X	O	O
074	0 ~ 1,600	0 ~ 160	X	O	O
075	0 ~ 2,000	0 ~ 200	X	O	O
027	-1 ~ 1	-0.1 ~ 0.1	-100 ~ 100	O	O
127	-1 ~ 1.5	-0.1 ~ 0.15	-100 ~ 150	O	O
028	-1 ~ 2	-0.1 ~ 0.2	-100 ~ 200	O	O
029	-1 ~ 3	-0.1 ~ 0.3	-100 ~ 300	O	O
030	-1 ~ 4	-0.1 ~ 0.4	-100 ~ 400	O	O
010	-1 ~ 5	-0.1 ~ 0.5	-100 ~ 500	O	O
031	-1 ~ 6	-0.1 ~ 0.6	-100 ~ 600	O	O
014	-1 ~ 9	-0.1 ~ 0.9	-100 ~ 900	O	O
032	-1 ~ 10	-0.1 ~ 1	-100 ~ 1,000	O	O
033	-1 ~ 15	-0.1 ~ 1.5	-100 ~ 1.5 MPa	O	O
034	-1 ~ 20	-0.1 ~ 2	-100 ~ 2 MPa	O	O
035	-1 ~ 25	-0.1 ~ 2.5	-100 ~ 2.5 MPa	O	O

O : Available X : Not available