

SANITARY PRESSURE GAUGE (3-A MARKING) MODEL : P752 SERIES

WISE[®]

SERVICE INTENDED

The P752 Series have diaphragm seal to be combined with pressure gauges. These series are suitable for corrosive, contaminated, hot or viscous pressure media in chemical, food, beverage, biochemical, pharmaceutical industry.

SPECIAL FEATURES

3A certificated
Suitable for SIP and CIP
All stainless, all welded construction for long life

NOMINAL DIAMETER

50mm, 63mm, 80mm and 100mm

ACCURACY

50mm : ± 3.0 % of full scale
63mm, 80mm and 100 mm : ± 1.6 % of full scale
- If scale range less than 100 psi : ± 2.0 % of full scale

SCALE RANGE

-0.1 vacuum to 7MPa, single

WORKING PRESSURE

Steady pressure : 75% of full scale value
Fluctuating pressure : 67% of full scale value



OPERATING TEMPERATURE

Ambient : -25°C to +60°C
Process : -3°C to +121°C

Standard Features

PRESSURE CONNECTION

3/4", 1", 1+1/2" and 2" Tri-clamp
Low and back

DIAPHRAGM AND SEAL HOUSING

Diaphragm : Stainless Steel (316LSS)
Seal housing : Stainless Steel (316SS)
(12 ~ 20 Ra Finish)

OPTION

Material of wetted parts : electropolished 316LSS

SYSTEM FILLING

USP grade glycerine (FDA approved)

MOVEMENT

Stainless steel (304SS)

DIAL

White aluminum, with pointer stop pin
With black/red lettering, dual pressure scale(psi/bar)

POINTER

Black aluminum pointer

CASE

Stainless steel (304SS) , electropolished with pressure relief

RING AND WINDOW

50mm : Twist-lock polycarbonate(Diameter 50mm)
60, 80 and 100mm :
• Stainless steel 304SS (Case & Cover)
• Safety glass (Window)

HELIUM LEAK RATE

Tested to confirm leakage rates of less than
 10^{-8} mbar • l / sec

ORDERING INFORMATION

BASE MODEL

P752 : Sanitary pressure gauge - Tri-clamp

GAUGE MODEL & MOUNTING TYPE

- 1A : 50mm, Bottom Connection (Refer to Code A)
- 7A : 63mm, Bottom Connection (Refer to Code A)
- 7N : 63mm, Lower Back Connection (Refer to Code G)
- 7U : 80mm, Bottom Connection (Refer to Code A)
- 7W : 80mm, Lower Back Connection (Refer to Code G)
- 8A : 100mm, Bottom Connection (Refer to Code A)
- 8N : 100mm, Lower Back Connection (Refer to Code G)

BODY & PROCESS CONNECTION MATERIAL

D : 316SS

PROCESS CONNECTION

- 34 : 3/4" Tri-clamp (only available nominal diameter 50 mm)
- 10 : 1" Tri-clamp (only available nominal diameter 63,80,100 mm)
- 12 : 1+1/2" Tri-clamp (only available nominal diameter 63,80,100 mm)
- 20 : 2" Tri-clamp (only available nominal diameter 63,80,100 mm)

UNIT

- H : bar
- ⊥ : MPa

RANGE

Refer to Pressure Unit & Range Table

DIAPHRAGM MATERIAL

E : 316LSS

OPTIONS

- 0 : None
- 1 : Accessories
- 2 : Electropolished 316LSS (wetted part)

P752	8A	D	10	H	047	E	0	SAMPLE MODEL NUMBER
-------------	-----------	----------	-----------	----------	------------	----------	----------	----------------------------

P752 : TYPE OF MOUNTING

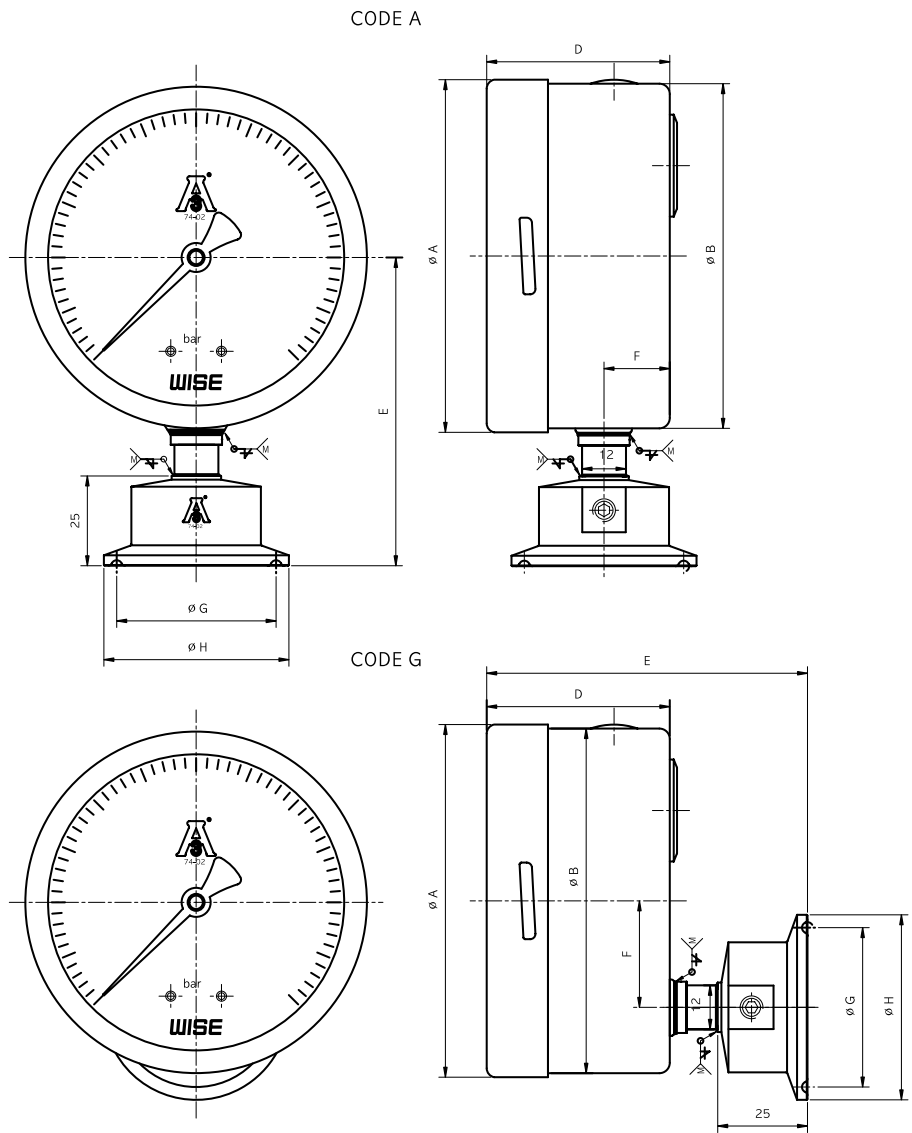

Dimensions (mm)

DIAL SIZE	CLAMP TYPE	AVAILABLE CODE	A	B	D	E	F	G	H
50	3/4"	A	53	50.8	29	68.3	9	19.5	25
63	1"	A*	63.7	62	33	75.7	11	43.5	50.5
	1+1/2"							43.5	50.5
	2"							56.5	64
	1"	G*	63.7	62	33	82.5	13	43.5	50.5
	1+1/2"							43.5	50.5
2"	56.5							64	
80	1"	A*	81.2	78.5	39.5	84	12	43.5	50.5
	1+1/2"							43.5	50.5
	2"							56.5	64
	1"	G*	81.2	78.5	39.5	91	22	43.5	50.5
	1+1/2"							43.5	50.5
2"	56.5							64	
100	1"	A*	101.3	99	50	100	16	43.5	50.5
	1+1/2"							43.5	50.5
	2"							56.5	64
	1"	G*	101.3	99	50	106.5	24	43.5	50.5
	1+1/2"							43.5	50.5
2"	56.5							64	

RANGE TABLE

RANGE & CODE	UNIT & CODE		PRESSURE CONNECTION			
	H : bar	I : MPa	3/4"	1"	1+1/2"	2"
026	-1	-0,1	×	○	○	○
040	0,5	0,05	×	○	○	○
041	1	0,1	×	○	○	○
133	1,6	0,16	×	○	○	○
042	2	0,2	○	○	○	○
134	2,5	0,25	○	○	○	○
043	3	0,3	○	○	○	○
044	4	0,4	○	○	○	○
045	6	0,6	○	○	○	○
047	10	1	○	○	○	○
050	15	1,5	○	○	○	○
143	16	1,6	○	○	○	○
051	20	2	○	○	○	○
052	25	2,5	○	○	○	○
054	35	3,5	○	○	○	○
151	40	4	×	○	○	○
055	50	5	×	○	○	○
056	60	6	×	○	○	○
057	70	7	×	○	○	○
027	+1	+0,1	×	○	○	○
127	-1~1,6	-0,1~0,16	×	○	○	○
028	-1~2	-0,1~0,2	○	○	○	○
129	-1~2,5	-0,1~0,25	○	○	○	○
029	-1~3	-0,1~0,3	○	○	○	○
030	-1~4	-0,1~0,4	○	○	○	○
010	-1~5	-0,1~0,5	○	○	○	○
031	-1~6	-0,1~0,6	○	○	○	○
014	-1~9	-0,1~0,9	○	○	○	○
032	-1~10	-0,1~1	○	○	○	○
033	-1~15	-0,1~1,5	○	○	○	○
034	-1~20	-0,1~2	○	○	○	○
035	-1~25	-0,1~2,5	○	○	○	○

○ : AVAILABLE × : NOT AVAILABLE