

SANITARY PRESSURE GAUGE MODEL : P757

WISE®

SERVICE INTENDED

The P757 Series designed for diaphragm seal to combined with pressure gauges. Suitable for corrosive, contaminated, hot or viscous pressure media in chemical and food process.

NOMINAL DIAMETER

63, 80 and 100mm

ACCURACY

63, 80mm : ± 1.6 PER DIN 16 005
100mm : ± 1.0 PER DIN 16 005

PRESSURE RANGE (MPa, kPa, bar)

Refer to Pressure Unit and Range Table
Depending on diaphragm size and process conditions

WORKING PRESSURE

Steady : 75% Full Scale
Over Range Protection : 130% of Full Scale

WORKING TEMPERATURE

Full Scale Temperature ratings of diaphragm seal depending on the filling liquid, material of wetted parts. Standard filling liquid are available for temperature range from -20°C to 150°C.



Standard Features

BODY

Stainless Steel (316SS)

PROCESS CONNECTION

Stainless Steel (316SS)
Screw Connection

DIAPHRAGM

Stainless Steel (316LSS)
Electropolished Diaphragm

ORDERING INFORMATION

BASE MODEL

P757 : FIXED SCREW TYPE SANITARY PRESSURE GAUGE

GAUGE MODEL & MOUNTING TYPE

- 7A : 63mm, Bottom Connection, P252 Series
- 7U : 80mm, Bottom Connection, P252 Series
- 8A : 100mm, Bottom Connection, P252 Series
- 7P : 63mm, Bottom Connection, P258 Series
- 8U : 80mm, Bottom Connection, P258 Series
- 8P : 100mm, Bottom Connection, P258 Series

BODY & PROCESS CONNECTION MATERIAL

D : 316SS

PROCESS CONNECTION

- FC : 3/4PT
- GC : 1PT
- HC : 1 1/4 PT
- FD : 3/4 NPT
- GD : 1NPT
- HD : 1 1/4 NPT
- ZZ : Other

UNIT

- I : MPa
- H : bar

RANGE

Refer to Pressure Unit & Range Table

DIAPHRAGM MATERIAL

- E : 316LSS
- Z : Other

OPTIONS

- O : None
- 1 : Accessories

P757	8A	D	FC	I	058	E	0	SAMPLE MODEL NUMBER
-------------	-----------	----------	-----------	----------	------------	----------	----------	----------------------------

Note

1. Max Temperature and Pressure of Process medium will be specified on Order Sheet.

P757 : TYPE OF MOUNTING

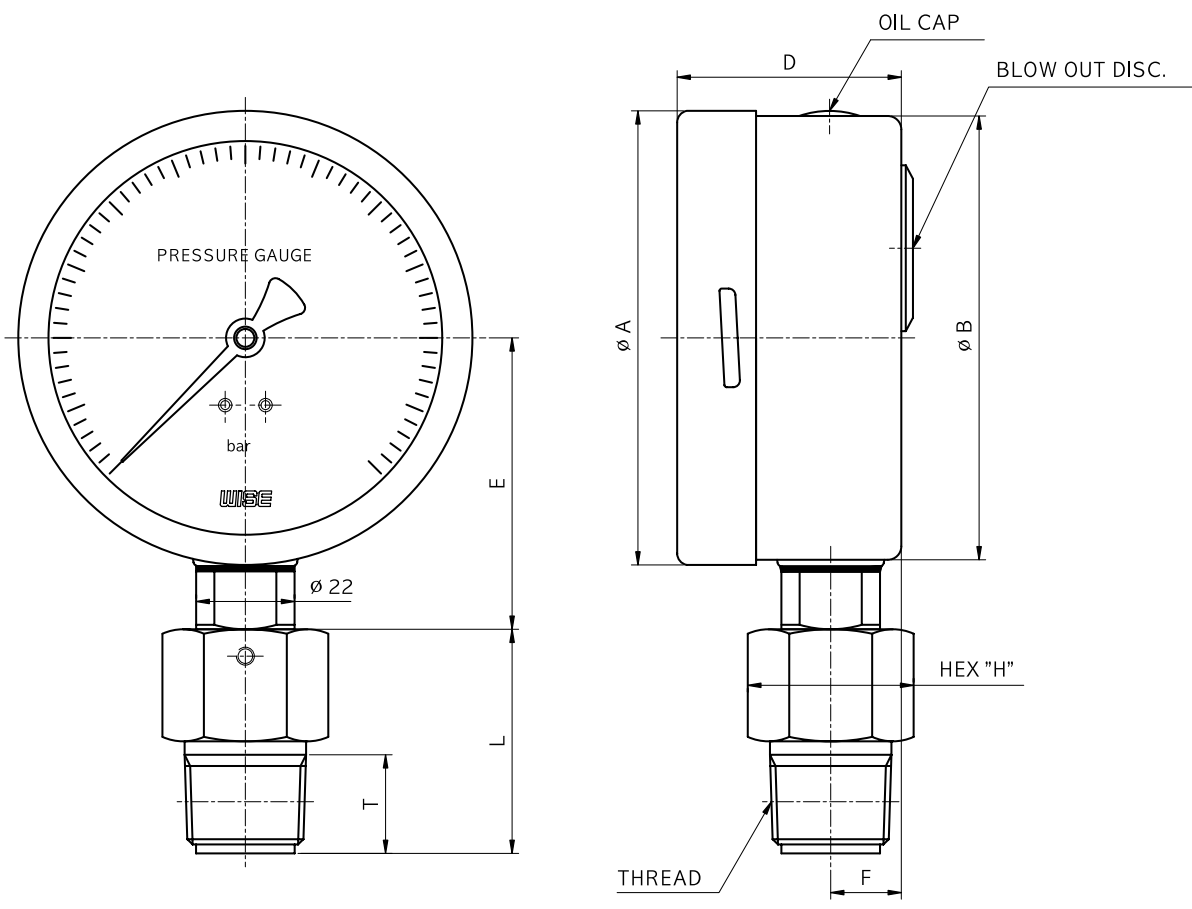

Dimensions (mm)

DIAL SIZE	A	B	D	E	F	THREAD	L	T	H
63	63.7	62	33	41.7	11	PT 3/4"	50	22	32X37 HEX.
						PT 1"	37	24	36X41.5 HEX.
80	81.2	79	39.5	48.5	12	PT 1 1/4"	43	24	46X53 HEX.
						NPT 3/4"	50	22	32X37 HEX.
100	101.3	99	50	65	16	NPT 1"	37	24	36X41.5 HEX.
						NPT 1 1/4"	43	24	46X53 HEX.

PRESSURE UNIT & RANGE TABLE

RANGE & CODE	UNIT & CODE		CONNECTION SIZE		
	H : bar	I : MPa	PT 3/4	PT 1	PT 1 1/4
045	0~6	0~0,6	○	○	○
047	0~10	0~1	○	○	○
050	0~15	0~1,5	○	○	○
143	0~16	0~1,6	○	○	○
051	0~20	0~2	○	○	○
052	0~25	0~2,5	○	○	○
054	0~35	0~3,5	○	○	○
151	0~40	0~4	○	○	○
055	0~50	0~5	○	○	○
056	0~60	0~6	○	○	○
057	0~70	0~7	○	○	○
058	0~100	0~10	○	○	○
059	0~150	0~15	○	○	○
060	0~160	0~16	○	○	○
062	0~250	0~25	○	○	○

○ : AVAILABLE × : NOT AVAILABLE