

Explosion proof type indicating pressure switch

Model: P990 series

Spec. sheet no. PD09-11

Service intended

P990 series explosion proof type indicating pressure switches are micro contact type. It is suitable to be used with corrosive fluid and it can measure a high pressure. Dead band is fixed.



Nominal diameter

125 mm

Repeatability

±1.0% of adjustable range

Adjustable range (MPa, kPa, bar)

-0.1 ~ 0 to -0.1 ~ 2 MPa

0 ~ 0.1 to 0 ~ 40 MPa

Accuracy

Indicator : ±1.5% of full scale

Switch setting : ±3% of full scale

Switch differential

Fixed, less than 6 ~15% of full scale

Working temperature

Ambient : -20 ~ 65°C

Fluid : Max. 100°C



Standard features

Element

C type bourdon tube,
Helical type bourdon tube

Case and cover

ALDC12.1
Silver gray painted aluminium

Process connection

3/8", 1/2" PT, NPT and PF

Setpoint adjustment

External

Conduit connection

3/4" PF (F)

Contact

Micro contact type
One SPDT or Two SPDT
One DPDT

Contact rating

- AC 125 V / 250 V, 15 A and DC 30 V, 2 A
DC 125 V, 0.5 A for resistance load
- AC 125 V / 250 V, 15 A and DC 30 V, 1 A
DC 125 V, 0.05 A for inductive load

Approval by standards

Explosion proof
Ex d IIC T6 (KGS)
Ex II 2G (LCIE 06 ATEX 6073X)
IECEx KGS-04-0001
Ex d IIC T6 (Tamb= -20 ~ + 60°C)
KOSHA 10-AV2B0-0272

1. Base model**P990** Explosion proof type indicating pressure switch**2. Nominal diameter (mm)****5** 125**3. Mounting****B** Bottom connection, surface, case mounting plate**4. Alarm type**

- 1** High alarm
- 2** High and low alarm
- 3** Low alarm
- 4** High and hi/high alarm
- 5** Low and lo/low alarm

5. Process connection

- D** $\frac{3}{8}$ "
- E** $\frac{1}{2}$ "

6. Connection type

- B** PF
- C** PT
- D** NPT

7. Unit

- H** bar
- I** MPa
- J** kPa

8. Range**XXX** Refer to pressure unit and range table**9. Dial color**

- 3** 2 color
- 7** 3 color

10. Options

- 0** None
- 1** Accessories

1	2	3	4	5	6	7	8	9	10
P990	5	B	1	D	B	H	XXX	3	0

Sample
ordering code

P990 : Type of mounting

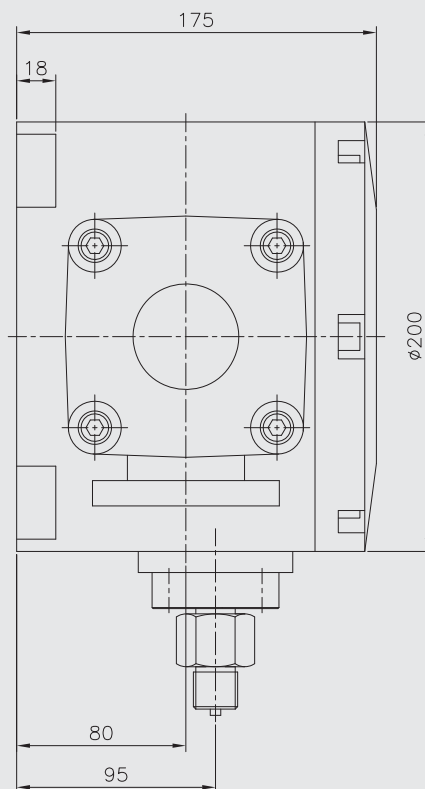
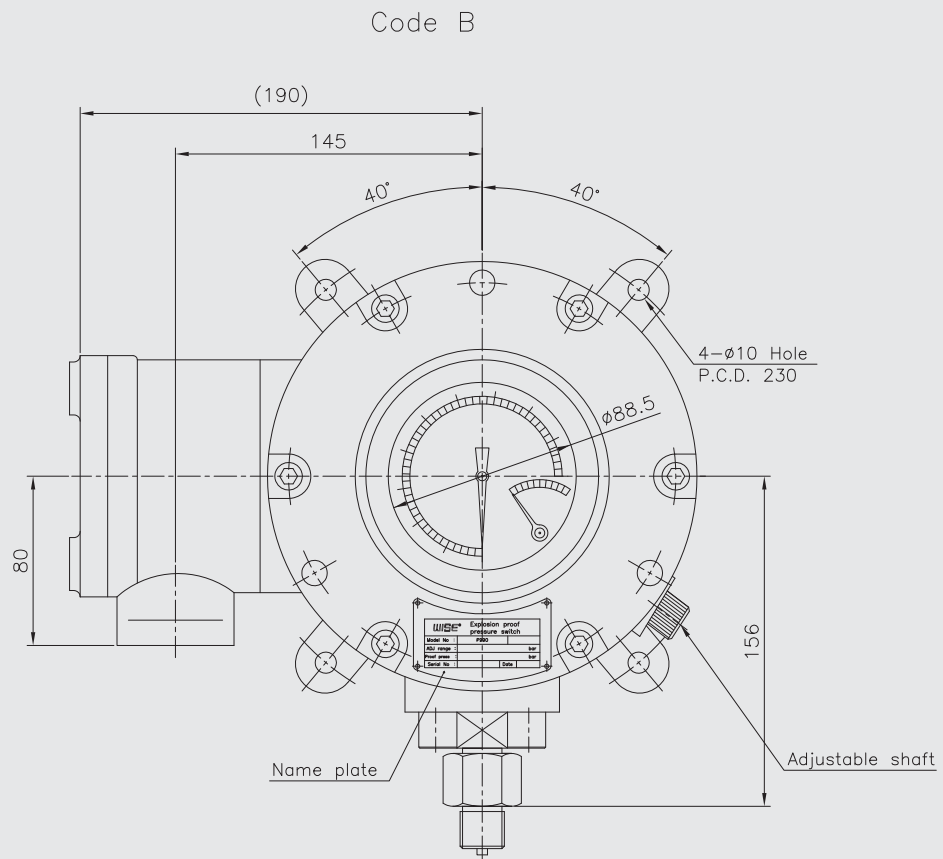

Range table

Range and code	Unit and code		
	H : bar	I : MPa	J : kPa
026	-1 ~ 0	-0.1 ~ 0	-100 ~ 0
040	0 ~ 0.5	0 ~ 0.05	0 ~ 50
041	0 ~ 1	0 ~ 0.1	0 ~ 100
042	0 ~ 2	0 ~ 0.2	0 ~ 200
043	0 ~ 3	0 ~ 0.3	0 ~ 300
044	0 ~ 4	0 ~ 0.4	0 ~ 400
045	0 ~ 6	0 ~ 0.6	0 ~ 600
047	0 ~ 10	0 ~ 1	0 ~ 1,000
050	0 ~ 15	0 ~ ~ 1.5	X
051	0 ~ 20	2	X
052	0 ~ 25	0 ~ 2.5	X
054	0 ~ 35	0 ~ 3.5	X
055	0 ~ 50	0 ~ 5	X
057	0 ~ 70	0 ~ 7	X
058	0 ~ 100	0 ~ 10	X
059	0 ~ 150	0 ~ 15	X
062	0 ~ 250	0 ~ 25	X
064	0 ~ 350	0 ~ 35	X
065	0 ~ 400	0 ~ 40	X
027	-1 ~ 1	-0.1 ~ 0.1	-100 ~ 100
028	-1 ~ 2	-0.1 ~ 0.2	-100 ~ 200
029	-1 ~ 3	-0.1 ~ 0.3	-100 ~ 300
030	-1 ~ 4	-0.1 ~ 0.4	-100 ~ 400
031	-1 ~ 6	-0.1 ~ 0.6	-100 ~ 600
032	-1 ~ 10	-0.1 ~ 1	-100 ~ 1,000
033	-1 ~ 15	-0.1 ~ 1.5	-100 ~ 1.5 MPa
034	-1 ~ 20	-0.1 ~ 2	-100 ~ 2 MPa

O : Available X : Not available